

Reference number:

**HSB**

**READ CAREFULLY BEFORE  
USE THE EQUIPMENT**

**SECTION 1 - GENERAL DATA**

**DESCRIPTION**

Aluminium gantry crane HSB series is a complete, lightweight, fully customizable (modular design), portable and flexible device designed to be used in variety of lifting applications such as, drainage wells, reservoirs, wells, silos, rooftop, lift-shaft, waste water and many more. For faster device installation additional tools are not needed (device installation - Section 2).

**BASIC PARAMETERS**

BEAMS: from 3 to 7 meters.  
 FRAMES: types - T1 / T2 / T3  
 Working Load Limit (WLL): from 3000kg up to 5000kg (depends on configuration - please see HSB Technical Data Table).  
 Safety factor for lifting loads: 2.1:1.  
 Safety factor for personal rescue: 10:1.  
 Protection for maximum five people at the same time.

**DEVICE USE SCENARIOS**

**1. Lifting loads only**

HSB can be used for lifting/lowering loads up to the related Working Load Limit (WLL - which is always indicated on the beam) with chain hoists, RUP50x-HT series devices and other lifting equipment. For lifting loads external trolley must be used.  
 Lifting loads - Section 3.

**2. Personal protection and lifting loads**

HSB device can be used for personal protection (max. 5 people at the same time) during lifting/lowering loads. During both operations at the same time (personal protection and lifting/lowering loads) WLL of the device indicated on the beam must be reduced - please refer to Section 3.  
For personal protection internal trolley must be used.  
 Personal protection - Section 4.  
 Lifting loads and personal protection at the same time - Section 5.

**3. Rescue and personal protection only.**

HSB device can be used for rescue purposes and personal protection as component of personal protective equipment against fall from height. During rescue operation lifting/lowering loads IS NOT allowed. For rescue RUP50x-H rescue lifting device must be used. For personal protection internal trolley must be used.  
 Rescue - Section 6.  
 Personal Protection - Section 4.



0000254

## GENERAL SAFETY INSTRUCTION

### INSPECTION BEFORE FIRST USE

HSB device must be visually and functionally inspected before first use by a competent person. Inspection must establish that all parts of the device are safe and has not been damaged by incorrect assembly, transport or storage. Inspections are carried out by the user.

### INSPECTION BEFORE WORKING

Before each use it is obligatory to carry out a pre-use check of the equipment, to ensure that it is in a serviceable condition and operates correctly before it is used. During pre-use check it is necessary to inspect all elements of the equipment in respect of any damages, excessive wear, corrosion, abrasion, cutting or incorrect acting. Especially take into consideration:

- components visual defects,
- test the trolleys for free movement along the beam,
- ensure that WLL of the device is sufficient for the application and will not be exceeded.

Inspections are carried out by the user.

### MAXIMUM LIFESPAN / PERIODIC INSPECTION

Maximum lifespan of the HSB device is unlimited but its depends on the intensity of usage and the environment of use. Using the device in rough environment, marine, contact with sharp edges, exposure to extreme temperatures or aggressive substances, etc. can lead to the withdrawal from use even after one use.

After every 12 months of utilization, equipment must be withdrawn from use to carry out periodical detailed inspection.

Periodic inspections must only be carried out by:

**FOR PERSONAL PROTECTION EQUIPMENT (PPE):** a competent person who has the knowledge and training required for personal protective equipment periodic inspections OR manufacturer OR manufacturer's authorized representative.

**FOR LIFTING EQUIPMENT (NON PPE):** a competent person responsible in the workplace for the interim inspection of lifting equipment.

Depending upon the type and environment of work, inspections may be needed to be carried out more frequently than once every 12 months.

During periodic inspection will be established admissible time of the device use till next periodic inspection.

The result of the periodic inspection must be recorded in Identity Card.

Regular periodic inspections are the essential for equipment maintenance and the safety of the users which depends upon the continued efficiency and durability of the equipment.

During periodic inspection it is necessary to check the legibility of the equipment marking.

### MAINTENANCE / STORAGE / REPAIR

If during the inspection any defects or damages are detected HSB device should be immediately withdraw from the use.

Do not change the device design, repair or replace elements included in the kit.

When using the device, protect it against mechanical, chemical and thermal damage. Do not use a damaged or malfunctioning parts. Clean a dirty device with a damp cloth. Store the device indoors, away from moisture and sources of heat.

### WITHDRAWAL FROM THE USE

Device must be withdrawn from use immediately when any doubt arise about its condition for safe use and not used again until confirmed in writing by equipment manufacturer or his representative after carried out the detailed inspection.

### TRANSPORT

The device should be transported in packaging protecting it from damage or getting wet, e.g. bags made of impregnated fabric or in steel / plastic / waterproof wooden cases or boxes.

### GENERAL PRECAUTIONS

- HSB device must be installed in accordance with this instruction manual.
- HSB device can be used in the temperature range from -20°C to +50°C.
- **Working Load Limit (WLL) indicated on the beam MUST NOT be exceeded.**
- **Working Load Limit (WLL) indicated on the beam MUST BE REDUCED to the RWWL value when personnel is protected (attached to the internal trolley) during lifting/lowering loads in accordance with Section 5.**
- During rescue operation lifting/lowering loads IS NOT allowed - please refer to Section 6.
- Each lifting operation must be properly planned and the weight of the load to be lifted must be known by the operator.
- Before any lifting operation all wheel brakes MUST BE locked.
- Equipment for lifting loads (e.g. hoists, chains) MUST BE attached ONLY to the external trolley attachment point.
- DO NOT attach load to the internal trolley. Internal trolley is intended to be used ONLY as personal protective equipment only.
- The operator must ensure that the additional lifting equipment (e.g. hoists, chains) are properly attached and not expose him or other personnel to danger.
- **HSB device can be moved under load only when a competent person or authority approves a risk assessment and method statement for a particular reason.**
- **Risk assessment and method statement must consider additional loading in "wet lift" situation.**
- Do not allow load to swing.
- Beam must be positioned horizontally during any lifting operation.
- Avoid side loads. Lift loads only when load chain is stretched in the vertical position between load and attachment point of lifting device.
- Do not lift or transport loads while personnel are in the danger zone.
- Personnel SHOULD NOT stand or pass under a suspended load.
- Suspended load MUST NOT be left unattended for a long period of time.
- BEFORE starting lowering the load ALWAYS make sure that personnel are not stand or pass under the load.

# HSB MAIN VIEW

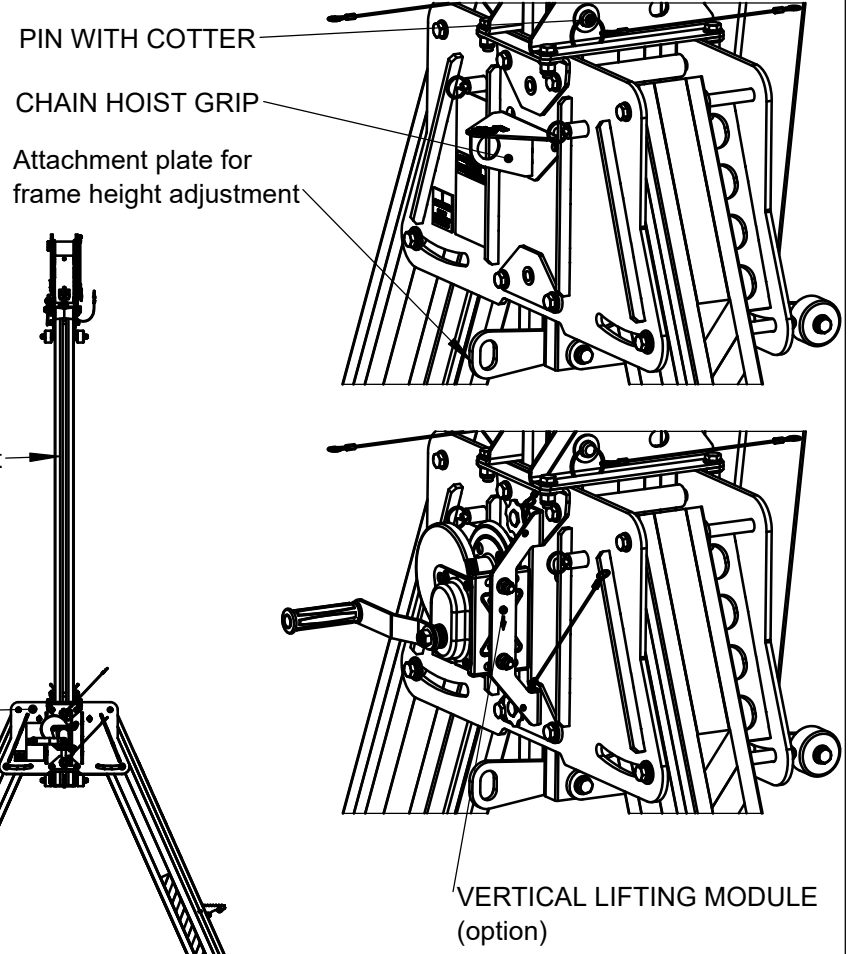
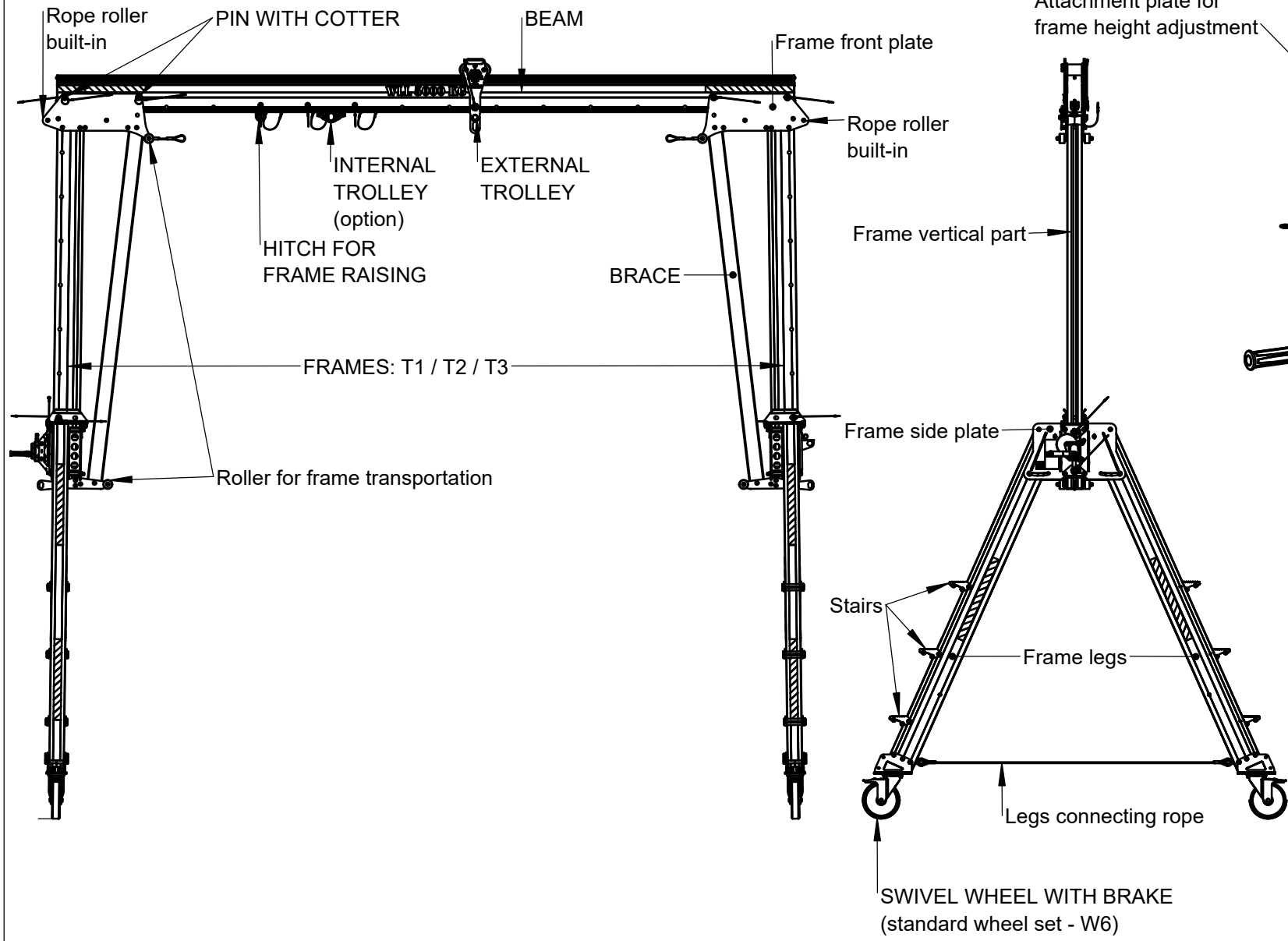

### HSB TECHNICAL DATA TABLE

'L' TOTAL BEAM LENGTH [mm]	'S' Working span [mm]	'S1' Bottom span [mm]	Beam weight [kg]	FRAME T1		FRAME T2		FRAME T3	
				WLL [T]	Total device weight [kg]	WLL [T]	Total device weight [kg]	WLL [T]	Total device weight [kg]
2000	695	1874	32	5	259	5	283	3	307
3000	1695	2874	48	5	275	5	299	3	323
4000	2695	3874	64	5	291	5	315	3	339
5000	3695	4874	80	5	307	5	331	3	355
6000	4695	5874	96	4	323	4	347	3	371
7000	5695	6874	112	3	339	3	363	3	387
Support Weight [kg]				111		123		135	
'H' - Support height (min...max) [mm]				2634...3834		2992...4792		3349...5749	
'H1' - Under roller height (min...max) [mm]				1786		2238		2699	
'D' - Legs spacing [mm]				2318		2725		3132	
'E' - Support height increment [mm]						300			

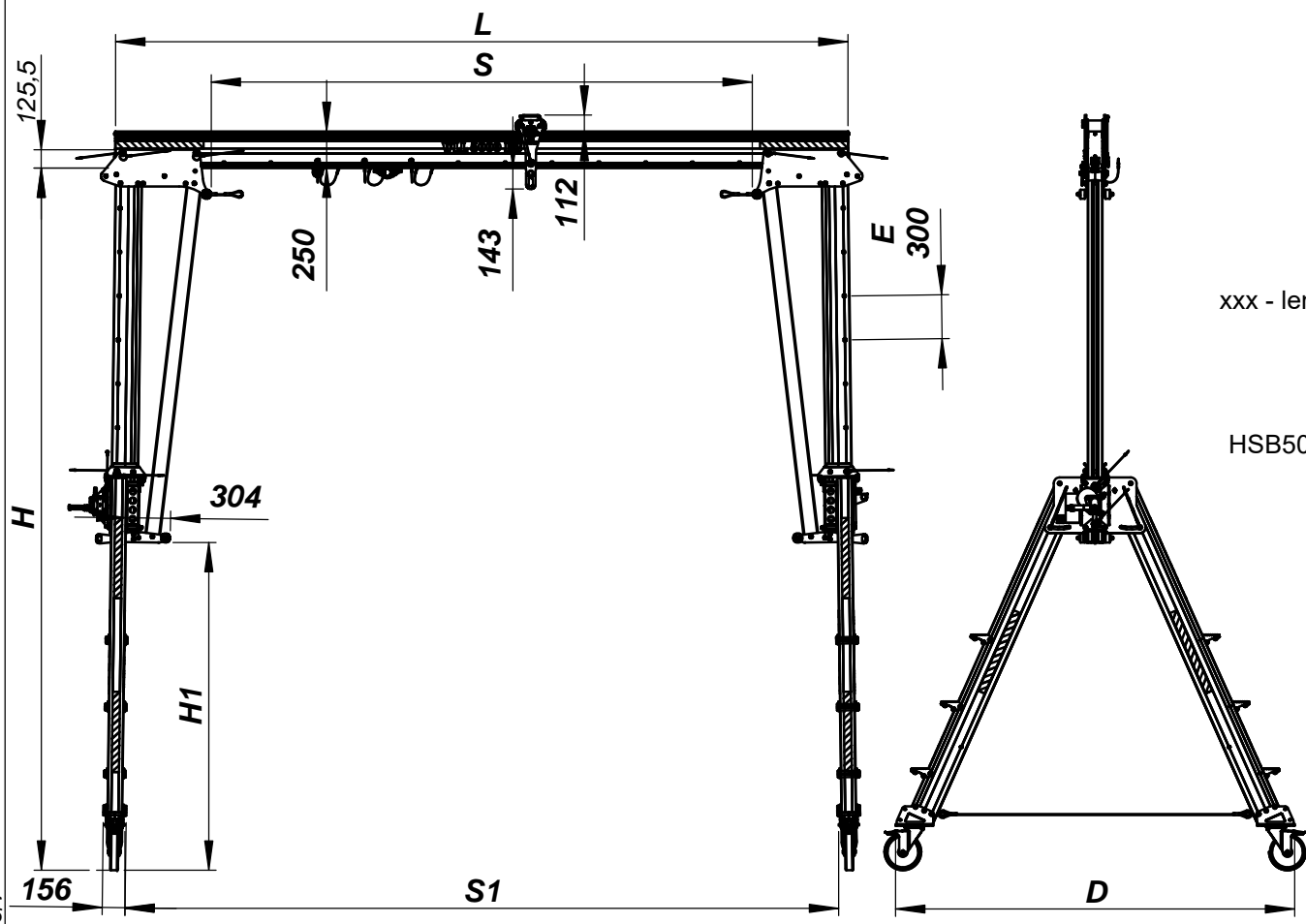

### HSB REFERENCE

**HSBxxx-yy-zz**

where:  
 xxx - length of the beam [cm] [200 / 300 / 400 / 500 / 600 / 700 / 800 / 900]  
 yy - support height option [T1 / T2 / T3]  
 zz - wheels set type [W4 / W5 / W6]

### EXAMPLE

HSB500-T2-W6 - 5-meter beam with support T1 with  $\phi$  250mm cast-iron with polyurethane tyre wheels.

# HSB FRAME TYPES

# HSB - REQUIRED INSTALLATION AREA [m x m]

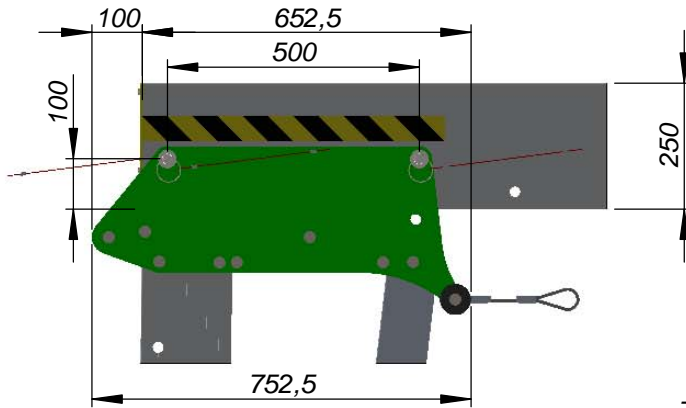

		3m	4m	5m	6m	7m
		FRAME	T1	2.5 x 9.5	2.5 x 10.5	2.5 x 11.5
	T2	3.0 x 10.3	3.0 x 11.3	3.0 x 12.3	3.0 x 13.3	3.0 x 14.3
	T3	3.5 x 11.1	3.5 x 12.1	3.5 x 13.1	3.5 x 14.1	3.5 x 15.1

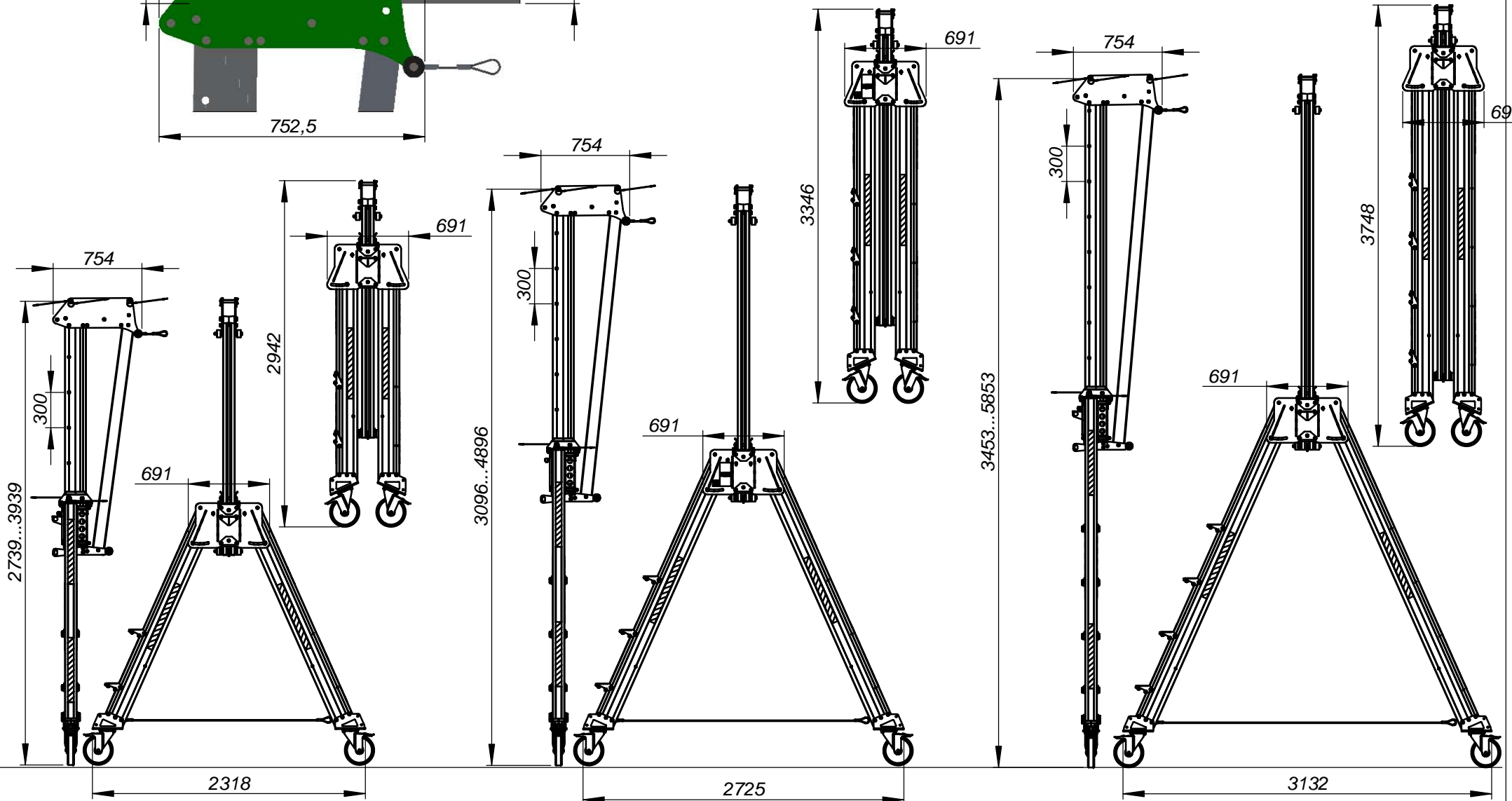

**T1 - SMALL**  
weight: 111 kg

**T2 - MEDIUM**  
weight: 123 kg

**T3 - LARGE**  
weight: 135 kg

## HSB BASIC EQUIPMENT

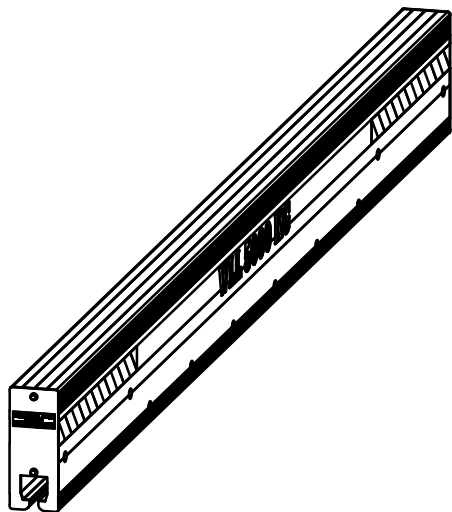

**HSB BEAM**  
 ref. HSB-BEAM-xxx  
 (where 'xxx' - beam length in cm]  
 Made of aluminium alloy with inside rail (for internal trolley). Can be used with external and internal trolleys.  
 Available beam length:  
3 / 4 / 5 / 6 / 7 m.

HSB Beam details:  
 Technical Data Table.

ONE in HSB basic set.

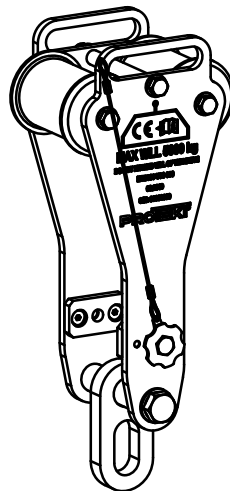

**MATERIAL TROLLEY (EXTERNAL)**  
 ref. HSB000-T01-000  
 Made of aluminium alloy, stainless steel and polyamide parts. Position can be locked along the beam using knob. External trolley can be used for lifting loads only.

ONE in HSB basic set.

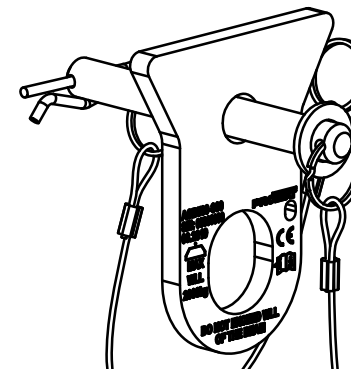

**HITCH FOR RAISING THE SUPPORT**  
 ref. ASB500-360  
 Made of aluminium alloy/galvanized steel. Used during raising and lowering the device frame. Chain hoist is attached to the hitch ear.

ONE in HSB basic set.

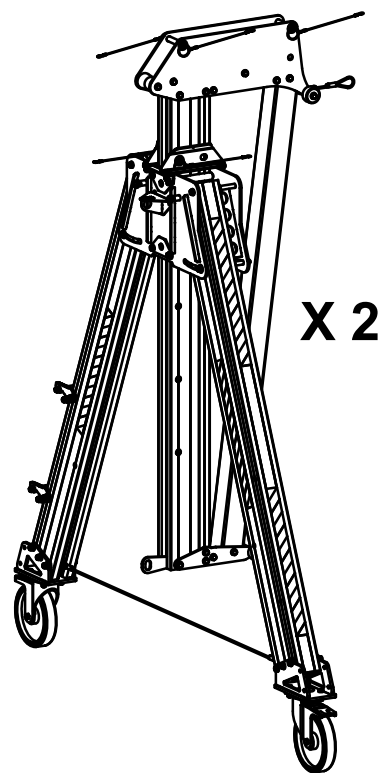

X 2

**HSB FRAME**  
 T1 - ref. HSB000-FT1-000  
 T2 - ref. HSB000-FT2-000  
 T3 - ref. HSB000-FT3-000

Made of aluminium alloy. Various height options. 300mm height adjustment. Foldable construction. Two the same frames are needed for one beam. Equipped with three bolts with cotter pin. Available support types:  
T1 / T2 / T3.

HSB Frame details:  
 Technical Data Table and Basic support types section.

TWO in HSB basic set.

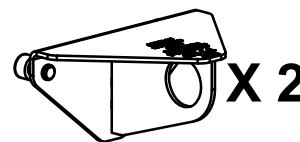

X 2

**CHAIN HOIST GRIP**  
 ref. ASB500-140

Made of stainless steel. Provides safety rising and lowering the frame vertical part during device installation on the working site. Chain hoist grip is installed on support's side plate. One piece is needed for one support.

TWO in HSB basic set.

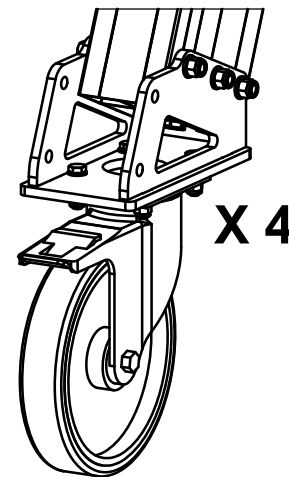

X 4

**WHEELS SET (4 pcs)**

Support can be equipped with three types of swivel wheels with brake depending on the site of use:

- **W4, ref. ASB100-040** -  $\varnothing$ 200mm cast iron with non-marking solid rubber tyre (polyurethan) - for cleanroom / manufacturing hall.
- **W5, ref. ASB100-050** -  $\varnothing$ 200mm aluminium with non-marking solid rubber tyre (polyurethan) - for cleanroom / manufacturing hall.
- **W6, ref. ASB100-060** -  $\varnothing$ 250mm cast iron with non-marking solid rubber tyre (polyurethan) - for cleanroom / manufacturing hall.

Complete ASB device must be equipped with four the same wheels.

Available types of wheels: W4 / W5 / W6.

It is recommended to use additionally Wheel Support set.

FOUR WHEELS W6 in HSB basic set.

## HSB ACCESSORIES

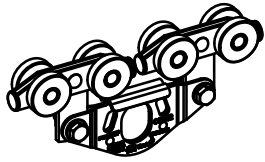

### PERSONAL TROLLEY (INTERNAL)

ref. ASB500-250

Made of galvanized and stainless steel. Space saving. Attachment point only 55mm under the beam. Position locking using bolts with cotter pin.

Internal trolley can be used **for personal protection purposes only**.

One trolley can be use for one person.

Max 5 trolleys on one HSB beam.

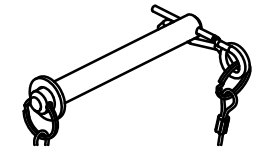

### BOLT WITH COTTER PIN 16mm

ref. ASB500-130

Made of galvanized steel. Used for:

- locking internal trolley position along the beam (two pieces for one internal trolley),
- locking rope roller for beam on the beam's holes (one piece for one rope roller for beam).

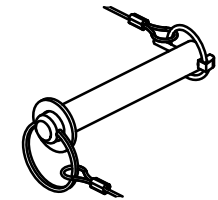

### BOLT WITH COTTER PIN 20mm

ref. PAD100-130

Made of galvanized steel. Used for:

- HSB - locking vertical part of the frame (one piece for one frame),
- HSB - locking beam between frame front plates (two pieces for one frame).

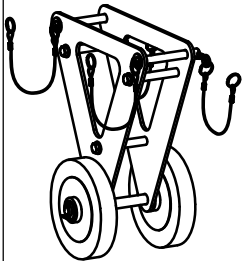

### BEAM TRANSPORTER

ref. ASB500-600

Made of aluminium alloy/galvanized steel parts.

Used for easy beam transportation on long distances.

Solid rubber wheels  $\varnothing$ 200mm.

Suits for ASB and LSB beams.

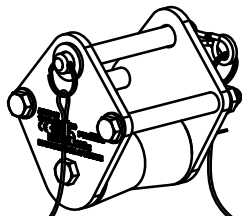

### ROPE ROLLER FOR BEAM

ref. ASB500-240

Made of reinforced aluminium alloy, stainless steel and polyamide parts.

Provides working rope guidance when RUP 50x-HT lifting device is used. Installed to the beam using bolts with cotter pin. Used also with CRW devices.



# HSB BEAM MARKING

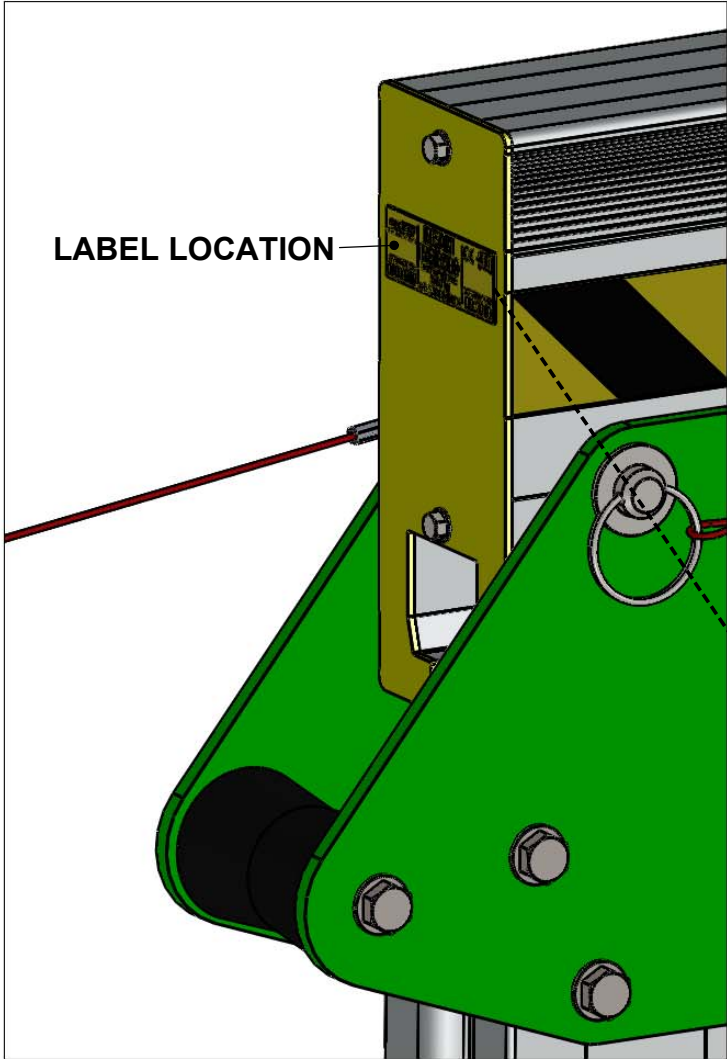

LABEL LOCATION

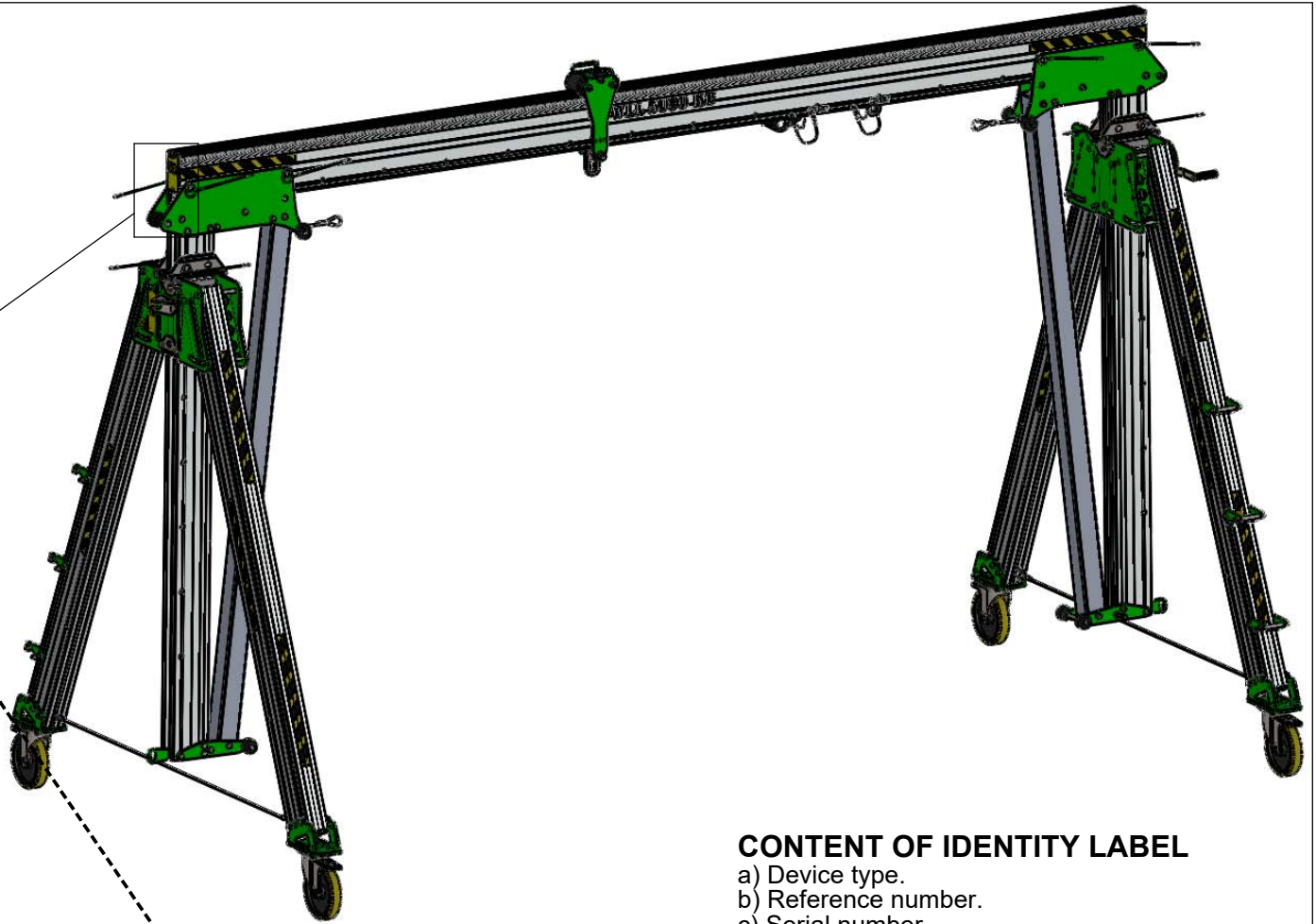

## CONTENT OF IDENTITY LABEL

- a) Device type.
- b) Reference number.
- c) Serial number.
- d) Month and year of manufacture.
- e) CE marking.
- f) Caution: Read the manual.
- g) Markig of the manufacturer or distributor.

## BEAM IDENTITY LABEL

<p><b>PROTEKT</b>  <small>STARORUDZKA S. 93-403 ŁÓDŹ          TEL.:+48 42 680 20 83; FAX:+48 42 680 20 93</small></p>	<p><b>BEAM          HSB500</b>          MAX WLL OF THE BEAM:  <b>5000 kg</b>          SERIAL NUMBER:  <b>00000000</b>          ref.: HSB-BEAM-500</p>	<p><b>CE</b>           DATE OF MANUFACTURE:  <b>09.2019</b></p>
---	---	--



## NEXT INSPECTION LABEL

Month and year of the manufacturer's next inspection. Don't use the device after this date. Attention: Before the first use mark the date of inspection (date of first use + 12 months, e.g. first use 01.2013 - mark inspection 01.2014). "Next inspection label" placed on Frame Identity Label.



# HSB FRAME MARKING

Technical drawing showing dimensions: H, H1, D, S1, E, 750, 57, 113, 112, 304, 136, 300.

**FRAME T2-W6** CE

SERIAL NUMBER: 00000000/A  
 FRAME LOAD MUST NOT EXCEED BEAM WLL  
 ref.: HSB000-FT2-W6  
 DATE OF MANUFACTURE: 09.2019

T1 TOTAL BEAM LENGTH [mm]	Beam weight [kg]	S' Working span [mm]	S1' Bottom span [mm]	T1 FRAME		T2 FRAME		T3 FRAME	
				WLL [T]	Total device weight [kg]	WLL [T]	Total device weight [kg]	WLL [T]	Total device weight [kg]
2000	32	695	1874	5	259	5	283	3	307
3000	48	1695	2874	5	275	5	299	3	323
4000	64	2695	3874	5	291	5	315	3	339
5000	80	3695	4874	5	307	5	331	3	355
6000	96	4695	5874	4	323	4	347	3	371
7000	112	5695	6874	3	339	3	363	3	387

Support Weight [kg]	111	123	136
.H' - Support height [mm]	2634...3834	2992...4792	3349...5749
.H1' - Under roller height [mm]	1786	2238	2599
.D' - Legs spacing [mm]	2318	2725	3132
E' - Support height increment [mm]	300 mm		

## CONTENT OF IDENTITY LABEL

- Device type.
- Reference number.
- Serial number.
- Month and year of manufacture.
- CE marking.
- Caution: Read the manual.
- Markig of the manufacturer or distributor.

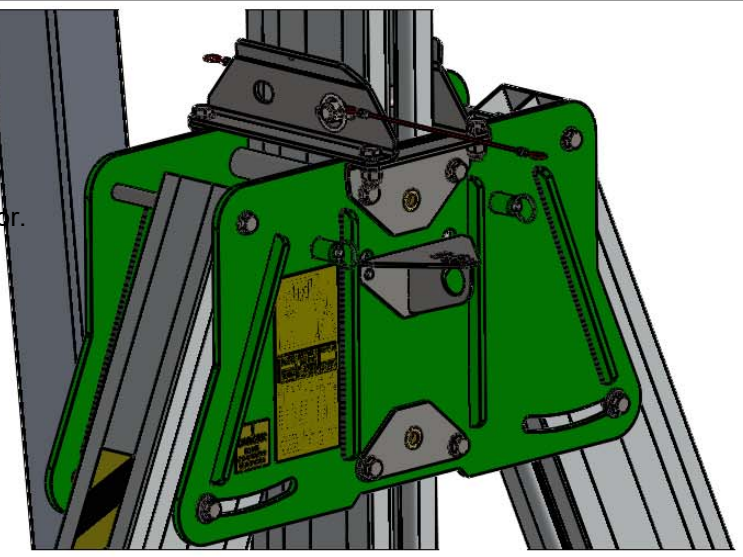

WLL TABLE PLATE

FRAME IDENTITY LABEL "/A" and "/B" serial number for both frames in SET



FRAME IDENTITY LABEL



## NEXT INSPECTION LABEL

Month and year of the manufacturer's next inspection. Don't use the device after this date.  
 Attention: Before the first use mark the date of inspection (date of first use + 12 months, e.g. first use 01.2013 - mark inspection 01.2014).  
 "Next inspection label" placed on Frame Identity Label.



# HSB GENERAL MARKING

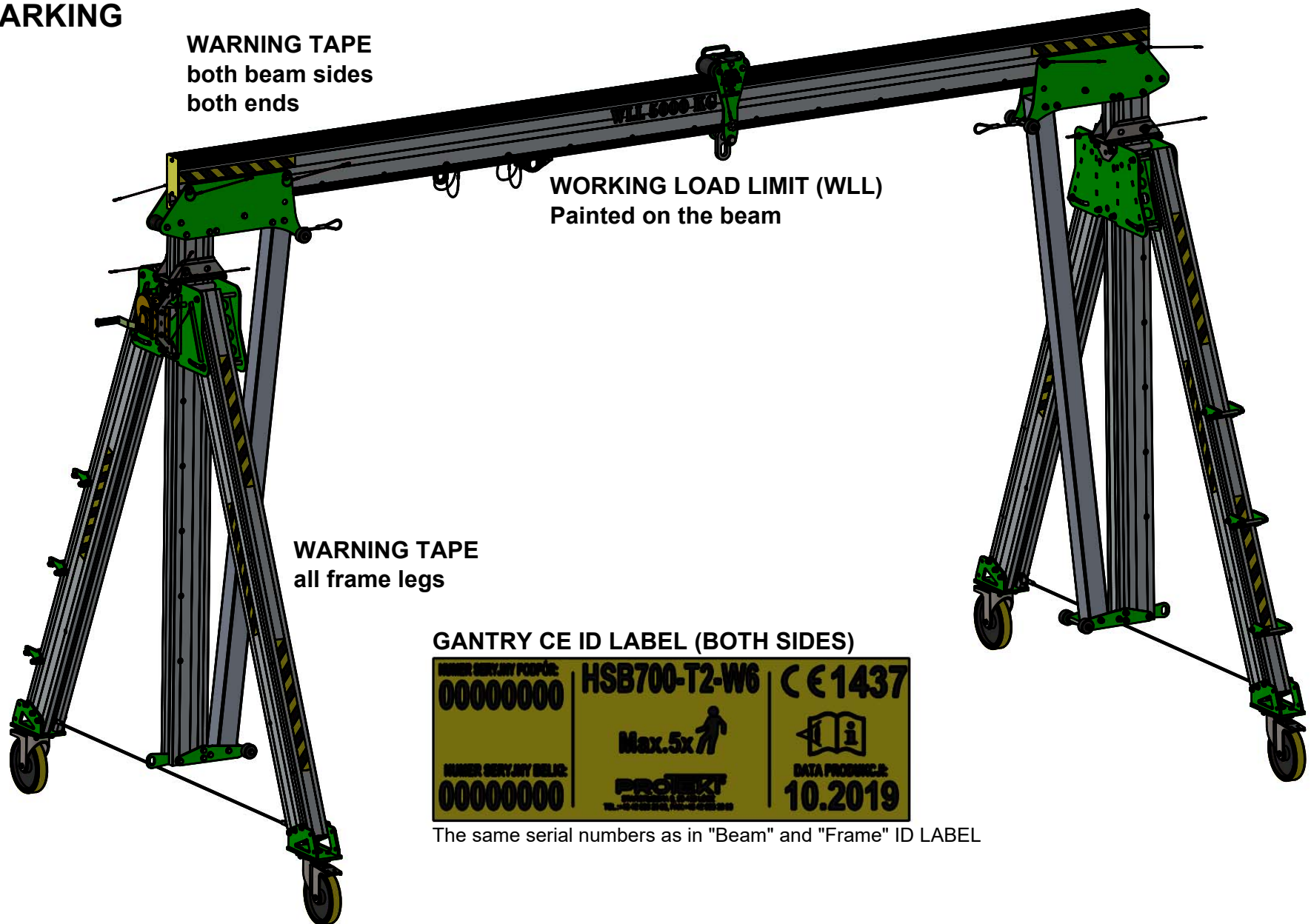

**WARNING TAPE**  
both beam sides  
both ends

**WORKING LOAD LIMIT (WLL)**  
Painted on the beam

**WARNING TAPE**  
all frame legs

**GANTRY CE ID LABEL (BOTH SIDES)**



The same serial numbers as in "Beam" and "Frame" ID LABEL

## NEXT INSPECTION LABEL

Month and year of the manufacturer's next inspection.  
Don't use the device after this date.  
Attention: Before the first use mark the date of inspection (date of first use + 12 months, e.g. first use 01.2013 - mark inspection 01.2014).  
"Next inspection label" placed on Frame Identity Label.



## CONTENT OF IDENTITY LABEL

- a) Reference number.
- b) Beam Serial number.
- c) Frame Serial number.
- d) Month and year of manufacture.
- e) CE marking.
- f) Caution: Read the manual.
- g) Marking of the manufacturer or distributor.
- h) Number of max. users.

## SECTION 2 - DEVICE INSTALLATION

2.1. HSB Beam can be easily transported using ASB500-600 Beam Transporter which can be installed to the beam using two bolts with cotter pin.

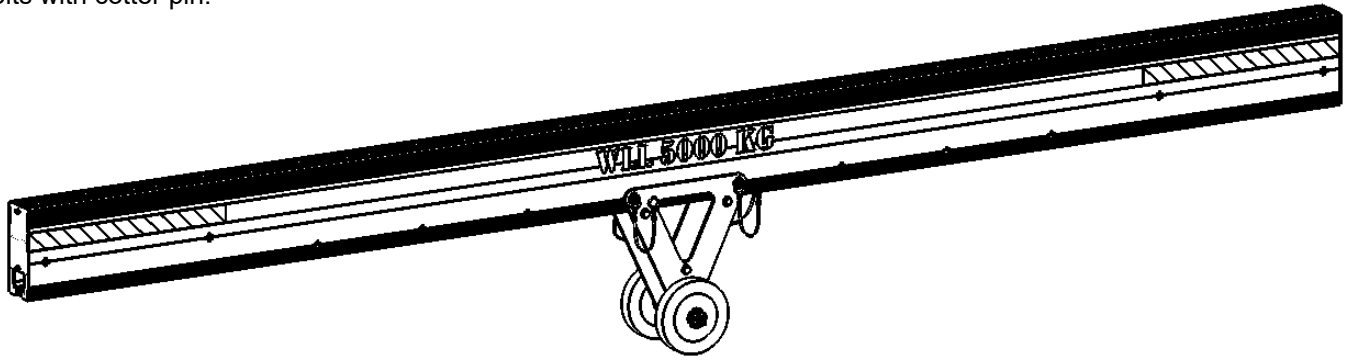

2.2. Place two frames and beam in the line on firm and flat surface.



**UNLOCK LOCKING PIN (PULL UP)  
HOLD AND OPEN THE LEG**

2.3. Open both frames legs unlocking the locking pin.

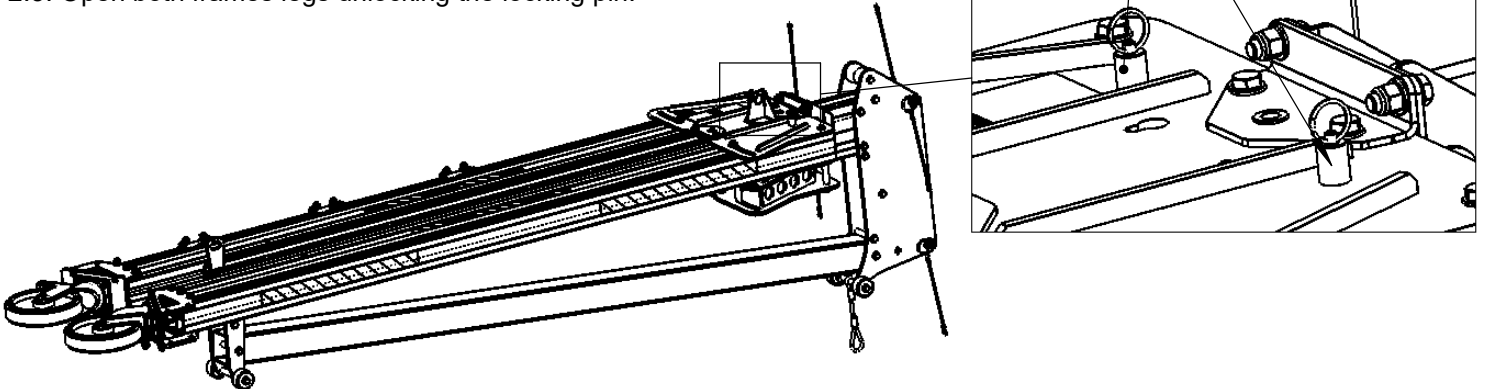

**AFTER FULL LEG OPEN  
LOCKING PIN WILL LOCK  
AGAIN (GOING DOWN)**

2.4. Fully opened legs of the HSB frame. Ready for Beam installation.

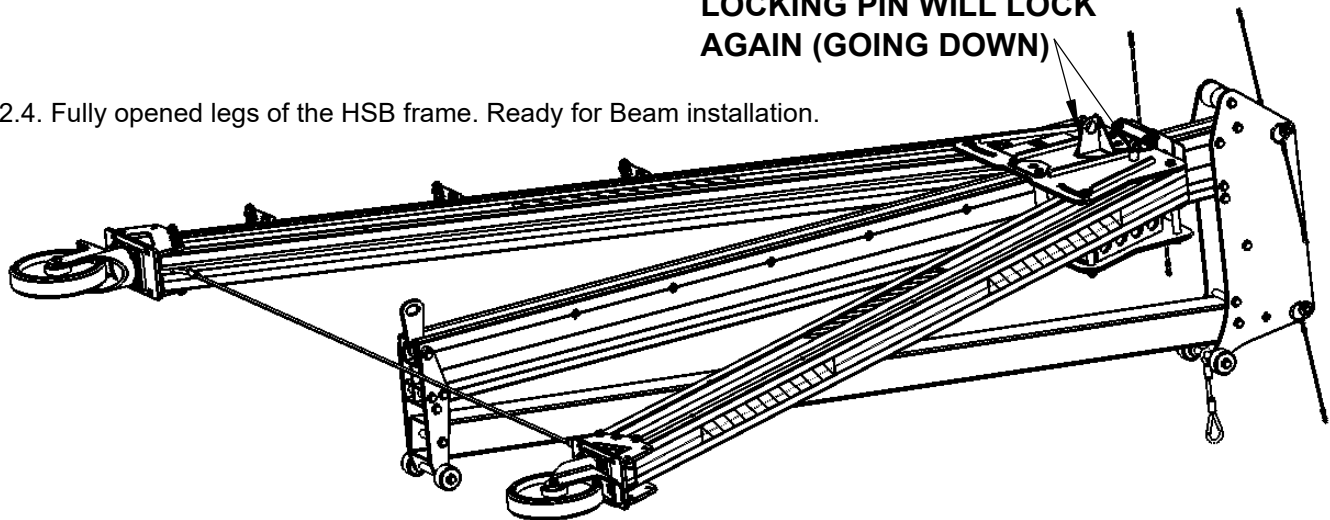



2.5. Connect first end of the beam to the frame using pin with cotter. For better stability frame legs should be opened.

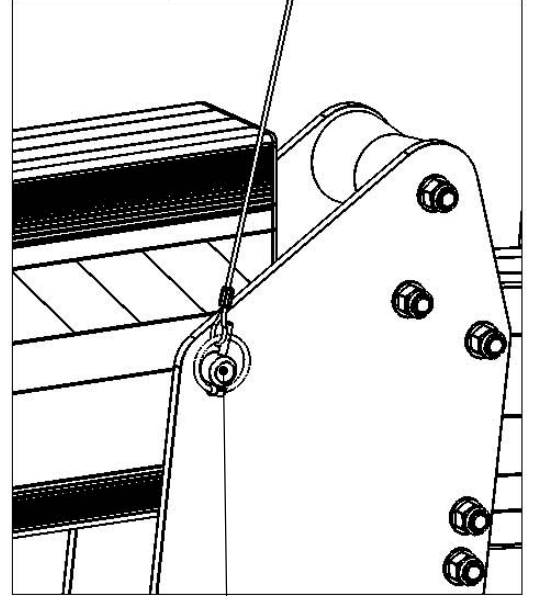
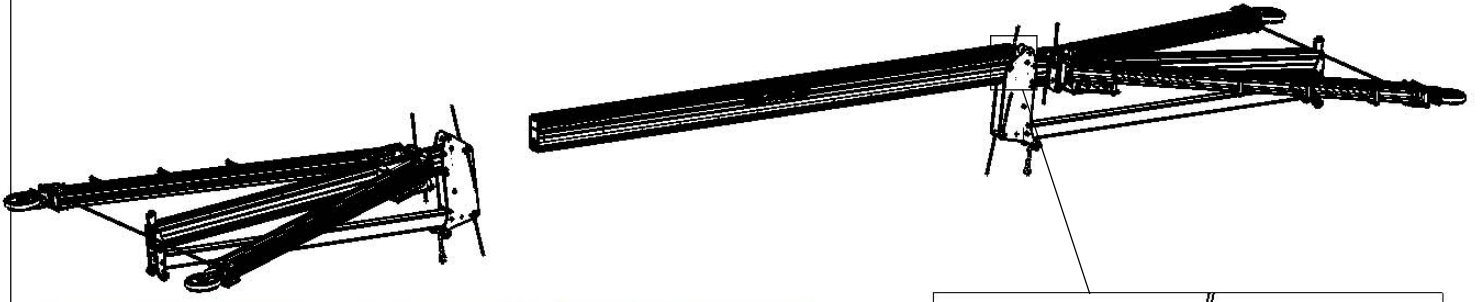

SECURE CONNECTION  
USING PIN WITH COTTER

- a) Remove Pin from front frame plate.
- b) Fit the beam between frame plates.
- c) Install Pin.
- d) Secure Pin with cotter.

2.6. Install ASB500-250 Internal trolley for personal protection (if used) before the second frame will be connected to the beam.

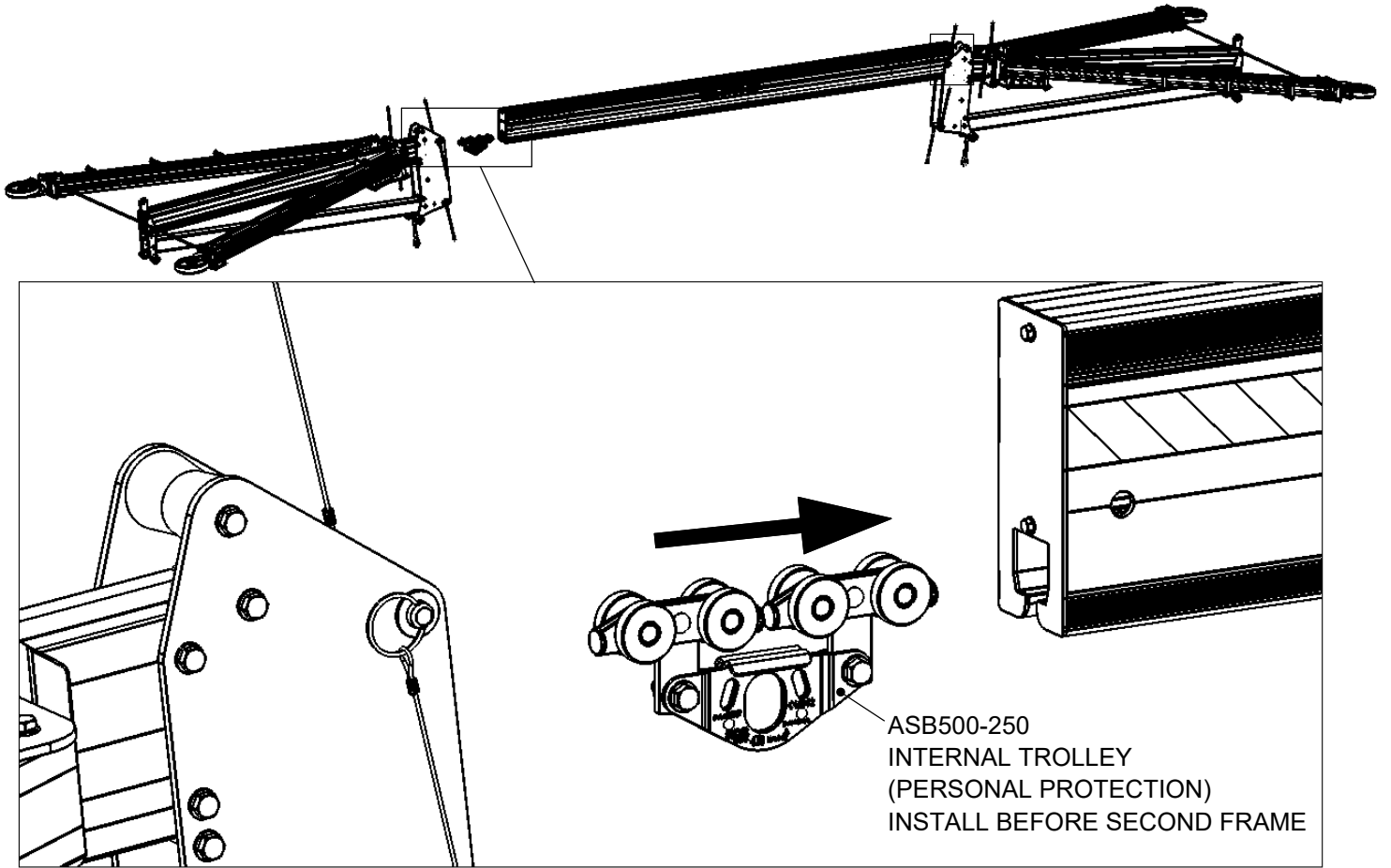

2.7. Secure internal trolley with two pins with cotter (against moving during raising up HSB device).

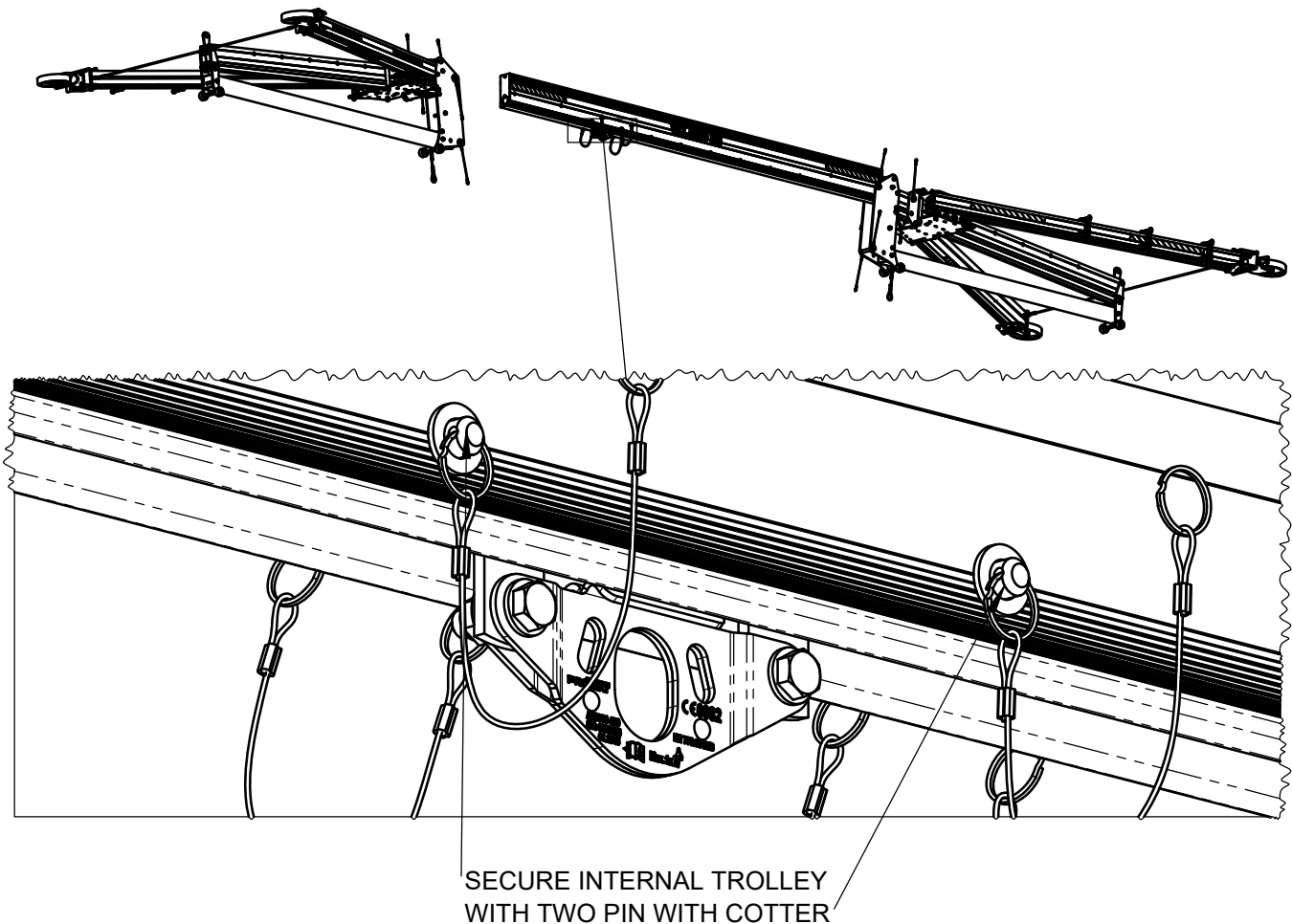

2.8. Connect second frame to the beam using pin with cotter. For better stability frame legs should be opened.

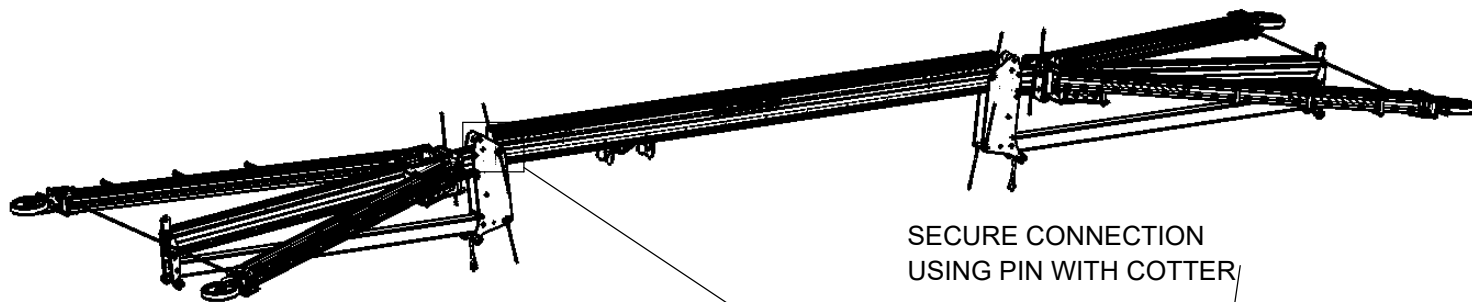

SECURE CONNECTION  
USING PIN WITH COTTER

- a) Remove Pin from front frame plate.
- b) Fit the beam between frame plates.
- c) Install Pin.
- d) Secure Pin with cotter.

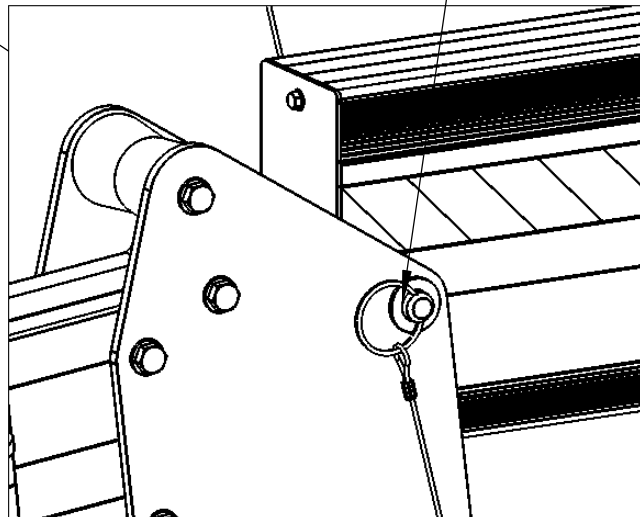

2.9. Install HSB000-T01-000 external trolley (for lifting materials).

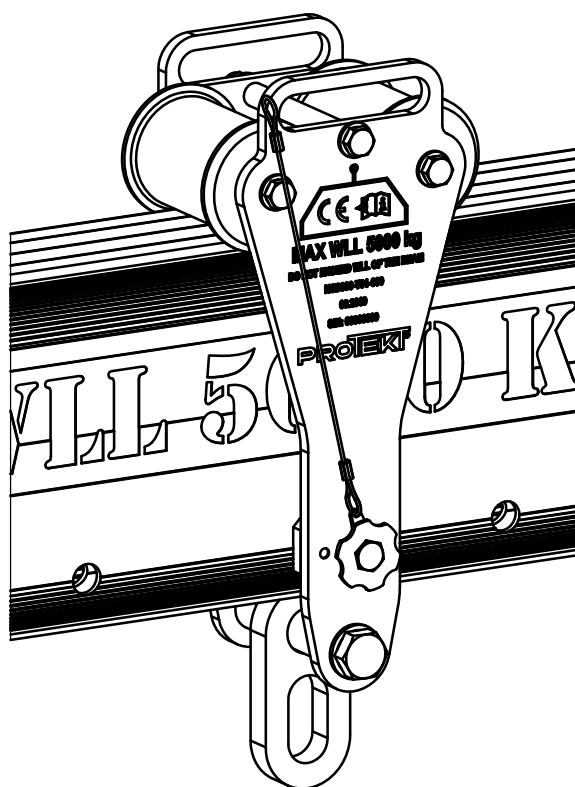
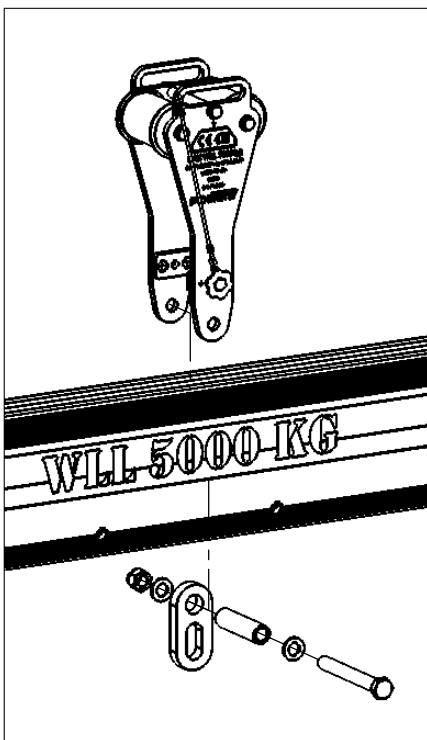
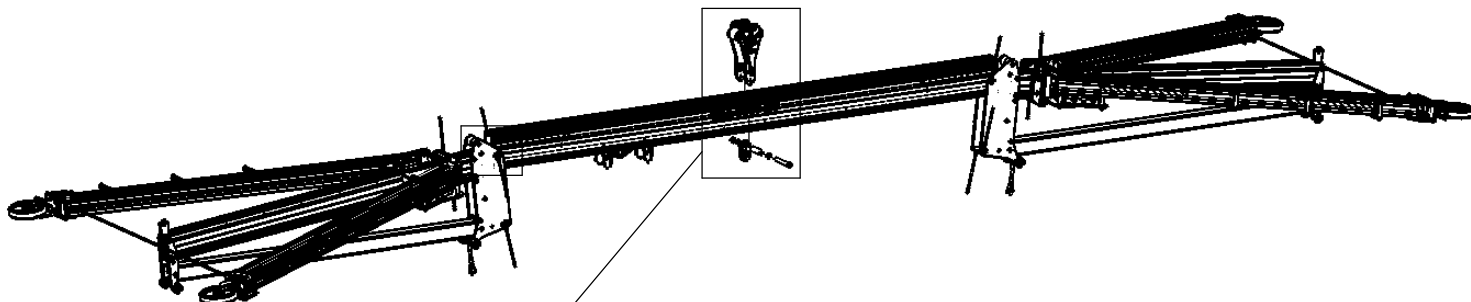



## 2.10. Raising frames.

It is recommended that frames should be raised using chain hoist (at least 1.5 tonne WLL) and hitch ASB500-360.

- Attach ASB500-360 hitch into third bottom line hole on the beam. Be sure hitch pin is secured by cotter.
- Attach chain hoist to the ASB500-360 hitch.
- Attach chain hoist hook to the end of the small steel rope located between frame front plates.
- Be sure that the lower pin from frame front plates is removed.
- Start raising frame using chain hoist lever.
- While raising watch the frame and beam stability.
- Lock first frame-beam connection using second pin with cotter.
- Secure Pin with cotter!
- Release chain hoist and disconnect both hooks. Remove ASB500-360 hitch.
- Repeat instructions for second frame.

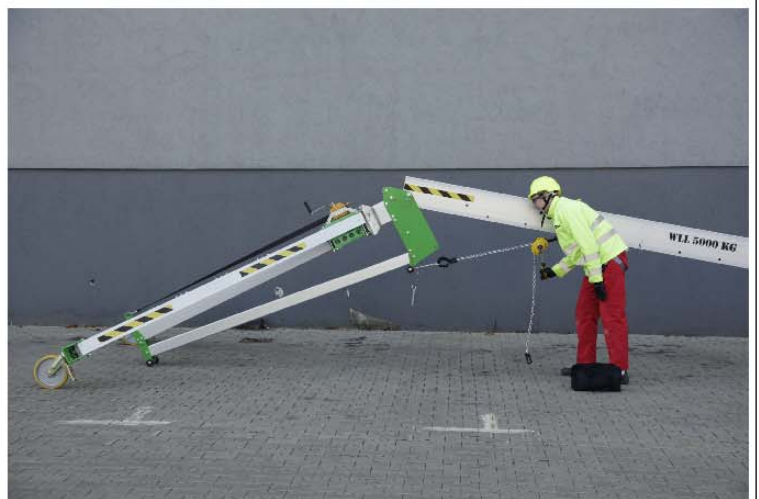



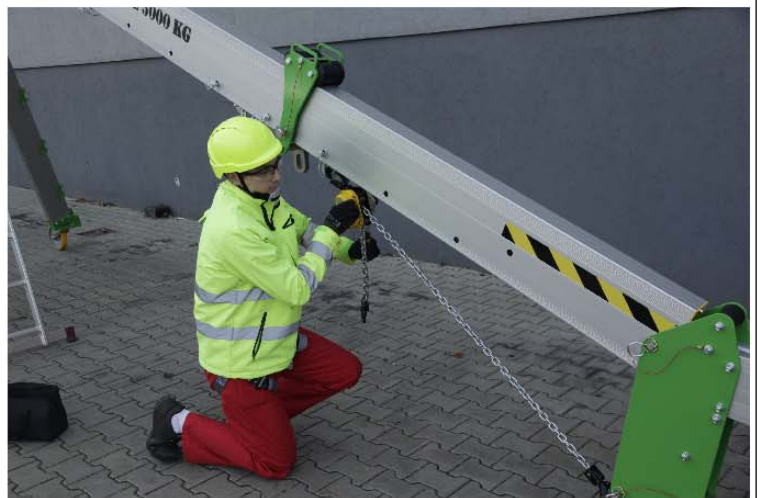
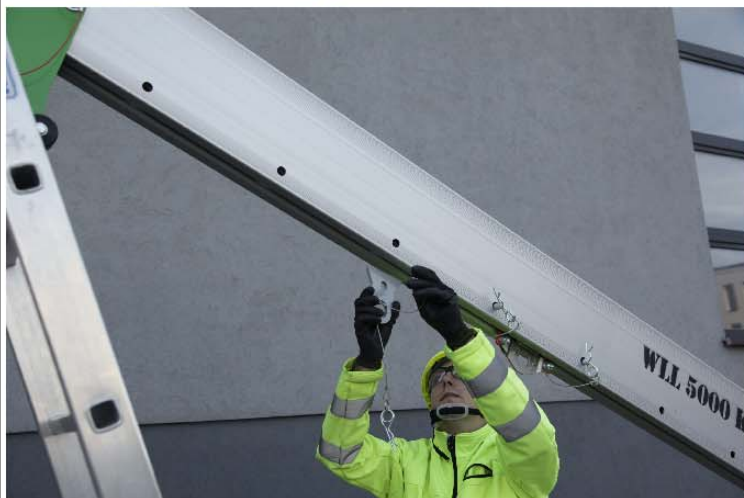
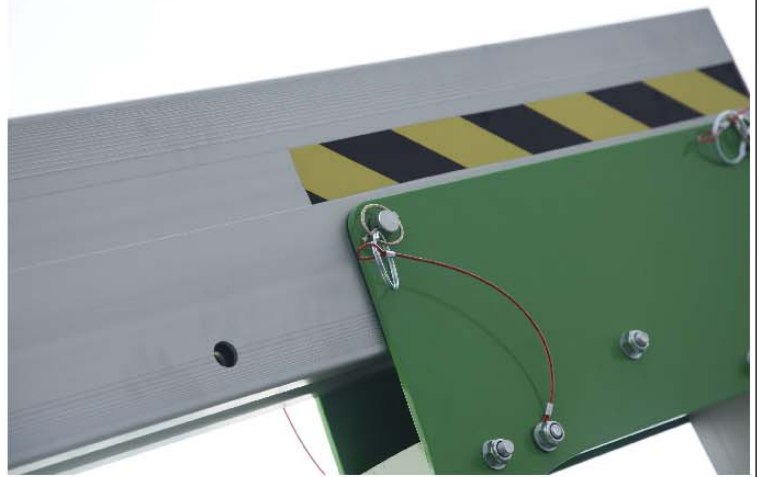

**ALWAYS SECURE PIN WITH COTTER!**





**ALWAYS  
SECURE PIN  
WITH  
COTTER!**



### 2.11. Beam height adjustment (using chain hoist and ASB500-140 holder)

- Hang ASB500-140 holder on frame side plate using two holes.
- Install chain hoist on ASB500-140 holder.
- Attach the chain hoist hook to the swivel plate on the vertical profile bottom end OR, If length of the chain is not enough ASB500-360, hitch can be used.
- Be sure that the chain hoist mechanism is locked and hook properly attached to the plate.
- Remove the pin with cotter installed between two stainless steel plates.
- Adjust (up or down) height of the frame vertical profile using chain hoist lever.
- After adjustment insert pin again throught the two stainless steel plates and secure it with cotter.



**ALWAYS SECURE PIN WITH COTTER!**

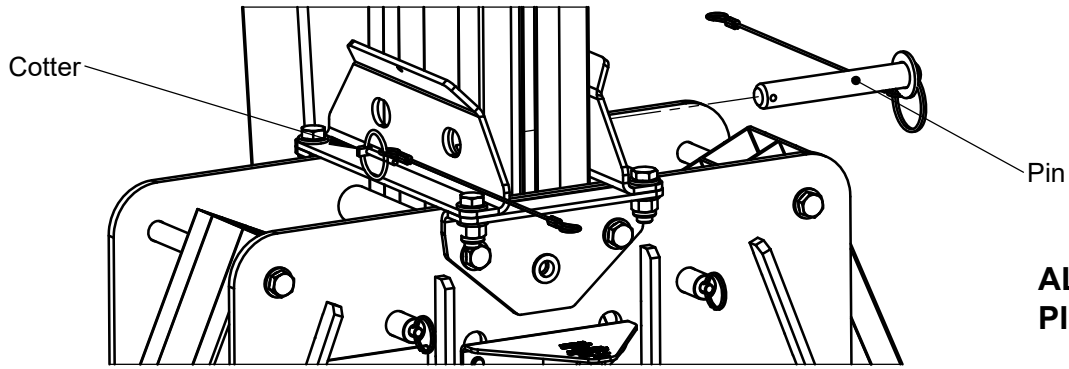

**ALWAYS SECURE  
PIN WITH COTTER!**



After height adjustment secure vertical profile with pin and cotter and release tension in chain (or remove chain hoist) before using device.

2.12. Before HSB lock wheel brakes.



**LOCK WHEEL BRAKES!**



2.13. Frame leg is equipped with steps which allows access to the frame side plate and vertical profile height adjustment or winch using when additional ladder is is ot available.

When steps are using it is recommended to use additionally ratractable type fall arrester connected to the internal trolley ASB500-250.

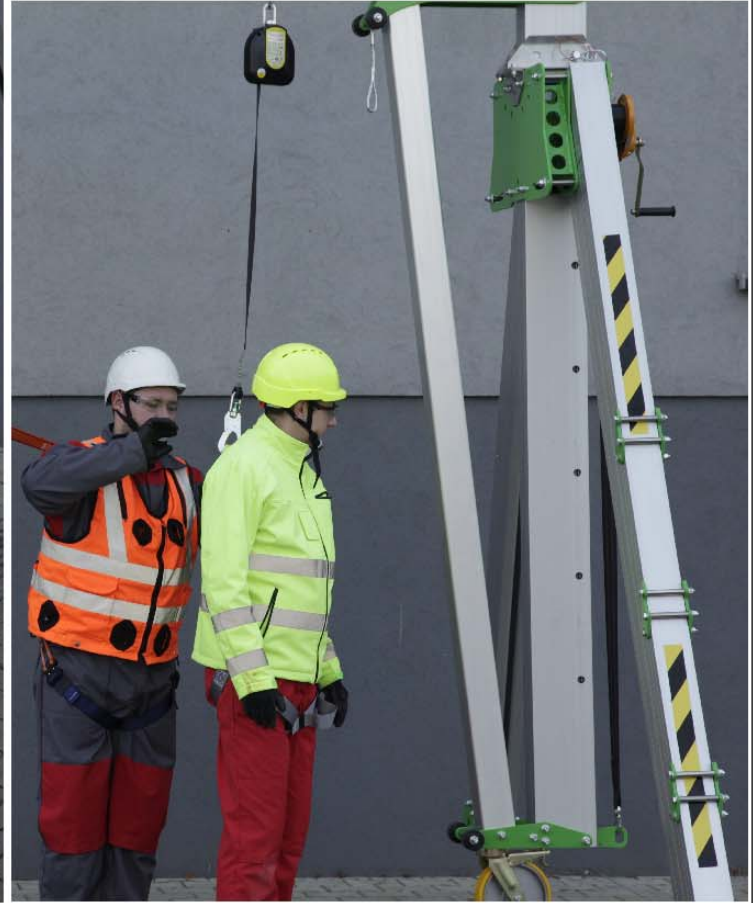



2.14. Beam height adjustment (using additional equipment - HSB000-A04-000 vertical lifting module)

- Install HSB000-A04-000 vertical lifting module to the frame side plate using two stainless steel knob.
- Pull the strap from the winch and attach the hook to the swivel plate on the vertical profile bottom end.
- Be sure that the hook is properly attached to the plate.
- Remove the pin with cotter installed between two stainless steel plates.
- Adjust (up or down) height of the frame vertical profile using chain hoist lever.
- After adjustment insert pin again through the two stainless steel plates and secure it with cotter.

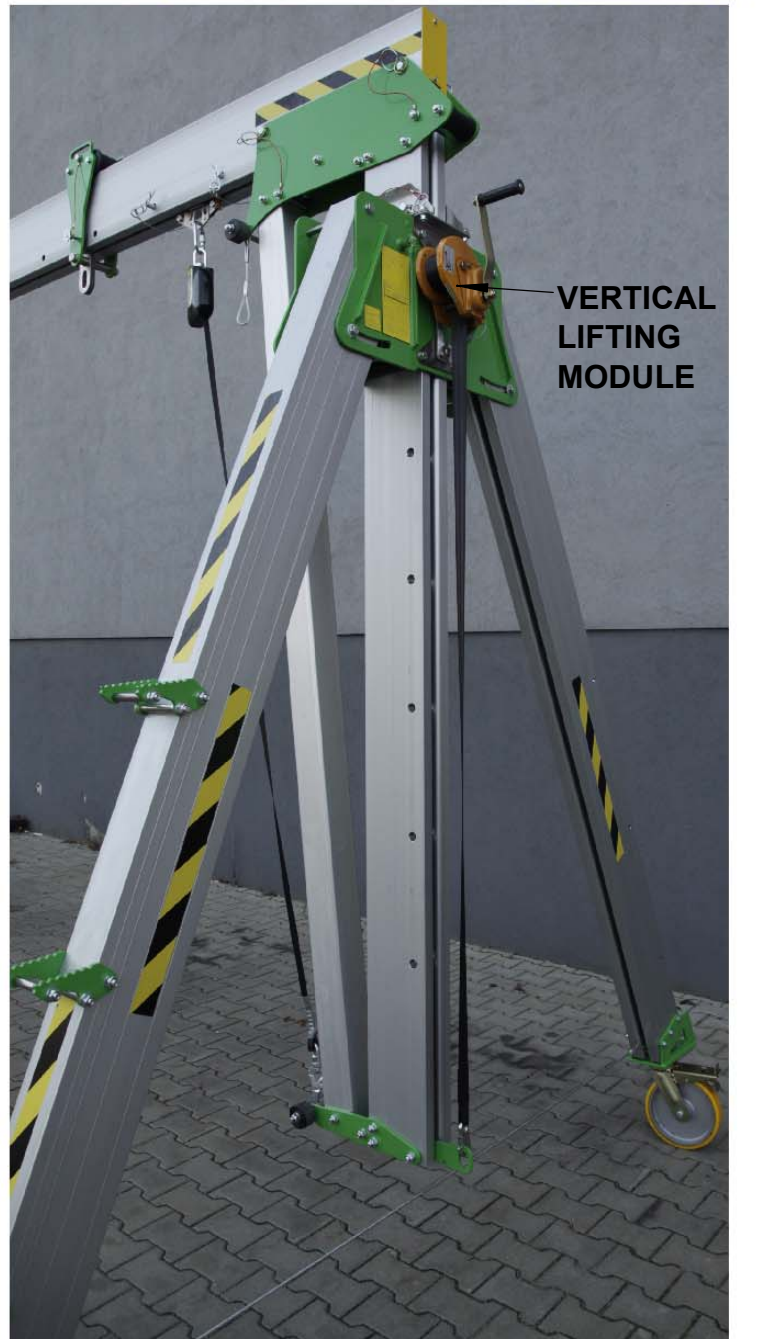

## SECTION 3 - LIFTING LOADS

External trolley HSB000-T01-000 can be used with HSB for lifting loads up to Working Load Limit (WLL) indicated on the beam. One beam can be used with more than one external trolley. Loads suspended on several external trolleys **MUST NOT** exceed WLL indicated on the beam. For personal protection during lifting loads please refer to Section 5.

**HSB000-T01-000 EXTERNAL TROLLEY  
ATTACHMENT POINT FOR LIFTING LOADS  
MAX WLL INDICATED ON THE BEAM.**

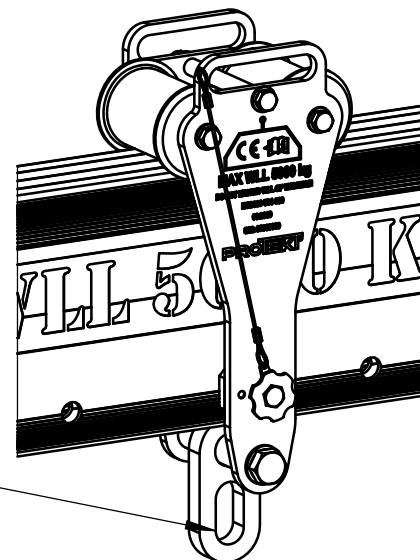

### DEVICE LOAD CARRYING CAPACITY

The load hoisted by the HSB device may be connected to the external trolley attachment point using chain hoists or other lifting devices with appropriate load carrying capacity. External trolley is installed on the beam. Maximum operating carrying capacity of the device is indicated on the beam.

DO NOT exceed Working Load Limit (WLL) indicated on the beam.

### GENERAL PRECAUTIONS FOR LIFTING LOADS

- HSB device is used for lifting and lowering loads weighing up to WLL indicated on the beam.
- External trolley is not an emergency device for lifting people and it should not be used for this purpose.
- Do not use a HSB device contrary to its intended use.
- Do not lift loads over an area occupied by people.
- Do not change the device design, repair or replaceable elements included in the kit.
- Before each use of the device, carry out thorough inspection to check the device condition and proper operation. Carefully check all parts, paying particular attention to any damage, excessive wear, corrosion, abrasion, cuts and malfunction.
- The device must be immediately withdrawn from use if there is any doubt about the condition of the device or its operation. The device may be readmitted for use only after a manufacturer's detailed inspection, and manufacturer's written consent for its use.
- Position ASB device on a flat, hard and stable surface, free of loose materials, such as rocks, debris etc.
- Check the stability of the load attached to the internal trolley attachment point or cable, on which it is hoisted, to prevent accidental detachment of any of the elements.
- The use of the device with other devices (such as devices for lifting and lowering loads) must be in accordance with the instruction for use of these devices.
- It is forbidden to use the kits in which the HSB device is included, in which the operation of any component disrupts the operation of other components.
- In case of any doubts as to the condition and usage of this device, please contact the manufacturer of the device.
- Avoid working where user may swing and hit an object or where lines may cross or tangle with that of another worker in the area.

### EXTERNAL TROLLEY MARKING

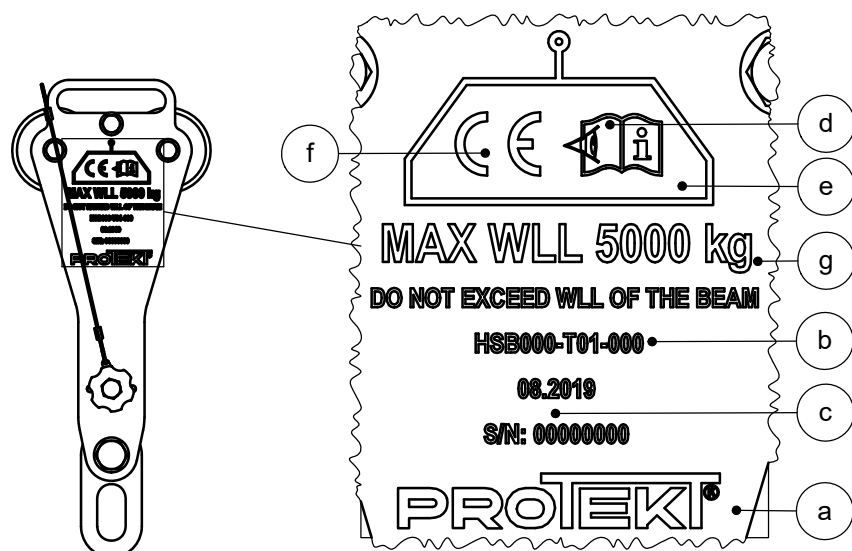

### CONTENT OF EXTERNAL TROLLEY MARKING:

- Marking of the manufacturer or distributor.
- Model symbol / reference number.
- Month and year of manufacture / Serial number.
- Caution: read the manual.
- Device for lifting loads.
- CE marking.
- Maximum Working Load Limit notice.



# SECTION 4

## PERSONAL PROTECTION ACCORDING TO EN 795 AND TS 16415

HSB with internal trolley (ASB500-250) can be used as a temporary anchorage according to EN 795 and TS 16415.

HSB device provides protection for maximum five people at the same time.

For personal protection during lifting loads please refer to Section 5.

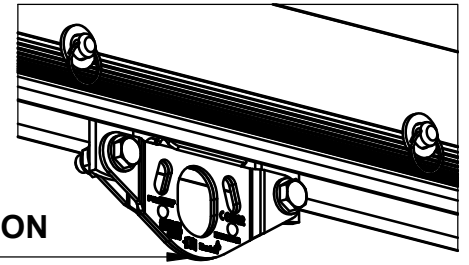

### ASB500-250 INTERNAL TROLLEY ATTACHMENT POINT FOR PERSONAL PROTECTION one person (EN 795)

**HSB MAX 5 pcs.**

#### **RULES FOR PERSONAL PROTECTION:**

1. ONE internal trolley can be used by ONE person at the same time.
2. For HSB maximum FIVE people can be attached to the available attachment points at the same time.
3. Anchor points designed for personal protection should ONLY be used for personal fall protection equipment and NOT for lifting equipment.

#### **GENERAL PRECAUTIONS**

- AVOID working where the user may swing and hit an object or where lines may cross or tangle with that of another worker in the area.
- Fall arrest and rescue systems used with this device MUST MEET applicable EN standards requirements (EN 795 for anchor devices; EN 362 for connectors; EN 361 for full body harnesses; EN 360 for retractable type fall arresters; EN 1496 for rescue lifting devices; EN 1497 for rescue harnesses; EN 341 for descender devices).
- The Maximum Arrest Force (MAF) to which a user of a Fall Arrest System (FAS), who wears a full body harness, is exposed during an arrest of his/her fall is limited by law 6 kN in EU. The system used to protect user against fall from height must include fall protection equipment reducing the Maximum Arrest Force, acting on the user while arresting the fall, to maximum value of 6kN (e.g. fall safety energy absorber with lanyard or retractable fall arrester).
- Make sure that device is installed in a upright position on a flat, stable and hard surface. The surface must support the load.
- DO NOT use HSB device for more than five people at the same time.
- It is recommended that the device should be transported and installed by minimum two people.
- The anchor device or anchor point for the fall arrest system should always be positioned, and the work carried out in such a way, as to minimize both the potential for falls and potential fall distance. The anchor device/point should be placed above the position of the user. The shape and construction of the anchor device/point shall not allowed to self-acting disconnection of the equipment. Minimal static strength of the anchor device/point is 12 kN. It is recommended to use certified and marked structural anchor point complied with EN 795.

#### **THE ESSENTIAL PRINCIPLES OF USE OF PERSONAL PROTECTIVE EQUIPMENT**

- Personal Protective Equipment (PPE) shall only be used by a person trained and competent in its safe use.
- PPE must not be used by a person with medical condition that could affect the safety of the equipment user in normal and emergency use.
- A rescue plan shall be in place to deal with any emergencies that could arise during the work.
- It is forbidden to make any alterations or additions to the equipment without the manufacturer's prior written consent.
- Any repair shall only be carried out by equipment manufacturer or his certified representative.
- PPE shall not be used outside its limitations, or for any purpose other than that for which it is intended.
- PPE should be a personal issue item.
- Before use ensure about the compatibility of items equipment assembled into fall arrest system. Periodically check connecting and adjusting of the equipment components to avoid accidental loosening or disconnecting of the components.
- It is forbidden to use combinations of items of equipment in which the safe function of any one item is affected by or interferes with the safe function of another.
- It is essential for the safety of the user that if the product is re-sold outside the original country of destination the reseller shall provide instruction for use, for maintenance, for periodic examination and for repair in language of the country in which the product is to be sold.
- A full body harness (conforming EN 361) is the only acceptable body holding device that can be used in a fall arrest system.
- On full body harness use only attaching points marked with big letter "A" to attach a fall arrest system.
- It is obligatory to verify the free space required beneath the user at the workplace before each occasion of use the fall arrest system, so that, in the case of a fall, there will be no collision with the ground or other obstacle in the fall path. The required value of the free space should be taken from instruction manual of used equipment.
- There are many hazards that may affect the performance of the equipment and corresponding safety precautions that have to be observed during equipment utilization, especially:
  - trailing or looping of lanyards or lifelines over sharp edges,
  - any defects like cutting, abrasion, corrosion,
  - climatic exposure,
  - pendulum falls,
  - extremes of temperature,
  - chemical reagents,
  - electrical conductivity.

## **INSPECTION**

Before each use of personal protective equipment it is obligatory to carry out a pre-use check of the equipment, to ensure that it is in a serviceable condition and operates correctly before it is used.

During pre-use check it is necessary to inspect all elements of the equipment in respect of any damages, excessive wear, corrosion, abrasion, cutting or incorrect acting, especially take into consideration:

- in full body harnesses and belts - buckles, adjusting elements, attaching points, webbings, seams, loops;
- in energy absorbers - attaching loops, webbing, seams, casing, connectors;
- in textile lanyards or lifelines or guidelines - rope, loops, thimbles, connectors, adjusting elements, splices;
- in steel lanyards or lifelines or guidelines - cable, wires, clips, ferrules, loops, thimbles, connectors, adjusting elements;
- in retractable fall arresters - cable or webbing, retractor and brake proper acting, casing, energy absorber, connector;
- in guided type fall arresters - body of the fall arrester, sliding function, locking gear acting, rivets and screws, connector, energy absorber;
- in connectors - main body, rivets, gate, locking gear acting;
- in tripods - legs, safety pins, eye bolts, feet, chain, connecting elements.

## **PERIODIC INSPECTION**

After every 12 months of utilization, personal protective equipment must be withdrawn from use to carry out periodical detailed inspection. The periodic inspection must be carried out by a competent person who has the knowledge and training required for personal protective equipment periodic inspections. The periodic inspection can be carried out also by the manufacturer or his authorized representative. In case of some types of the complex equipment e.g. some types of retractable fall arresters the annual inspection can be carried out only by the manufacturer or his authorized representative.

During this inspection will be established admissible time of the device use till next manufacturer's inspection.

The result of the inspection must be recorded in Identity Card.

Regular periodic inspections are the essential for equipment maintenance and the safety of the users which depends upon the continued efficiency and durability of the equipment.

During periodic inspection it is necessary to check the legibility of the equipment marking.

## **MAXIMUM LIFESPAN**

Maximum lifespan of the ASB500-250 internal trolley is unlimited but its depends on the intensity of usage and the environment of use. Using the device in rough environment, marine, contact with sharp edges, exposure to extreme temperatures or aggressive substances, etc. can lead to the withdrawal from use even after one use.

## **WITHDRAWAL FROM USE**

Personal protective equipment must be withdrawn from use immediately when any doubt arise about its condition for safe use and not used again until confirmed in writing by equipment manufacturer or his representative after carried out the detailed inspection.

## **WITHDRAWN FROM USE AFTER ARRESTING A FALL**

Device must be withdrawn from use immediately when it have been used to arrest a fall. After that must be carried out detailed manufacturer's inspection of the tripod.

The manufacturer's inspection can be carried out by:

- manufacturer
- person recommended by manufacturer
- company recommended by manufacturer.

During this inspection will be established if the tripod can be longer used and will be define the admissible time of tripod use till next manufacturer's inspection and recorded in Identity Card.

## **TRANSPORTATION**

Personal protective equipment must be transported in the package (e.g.: bag made of moisture-proof textile or foil bag or cases made of steel or plastic) to protect in against damage or moisture.

## **MAINTENANCE AND STORAGE**

The equipment can be cleaned without causing adverse effect on the materials in the manufacture of the equipment. For textile products use mild detergents for delicate fabrics, wash by hand or in a machine and rinse in water. Plastic parts can be cleaned only with water. When the equipment becomes wet, either from being in use or when due cleaning, it shall be allowed to dry naturally, and shall be kept away from direct heat. In metallic products some mechanic parts (spring, pin, hinge, tec.) can be regularly slightly lubricated to ensure better operation. Other maintenance and cleaning procedures should be adhered to detailed instructions stated in the manual of the equipment.

Personal protective equipment should be stored loosely packed, in a well-ventilated place, protected from direct light, ultraviolet degradation, damp environment, sharp edges, extreme temperatures and corrosive or aggressive substances.

## INTERNAL TROLLEY MARKING

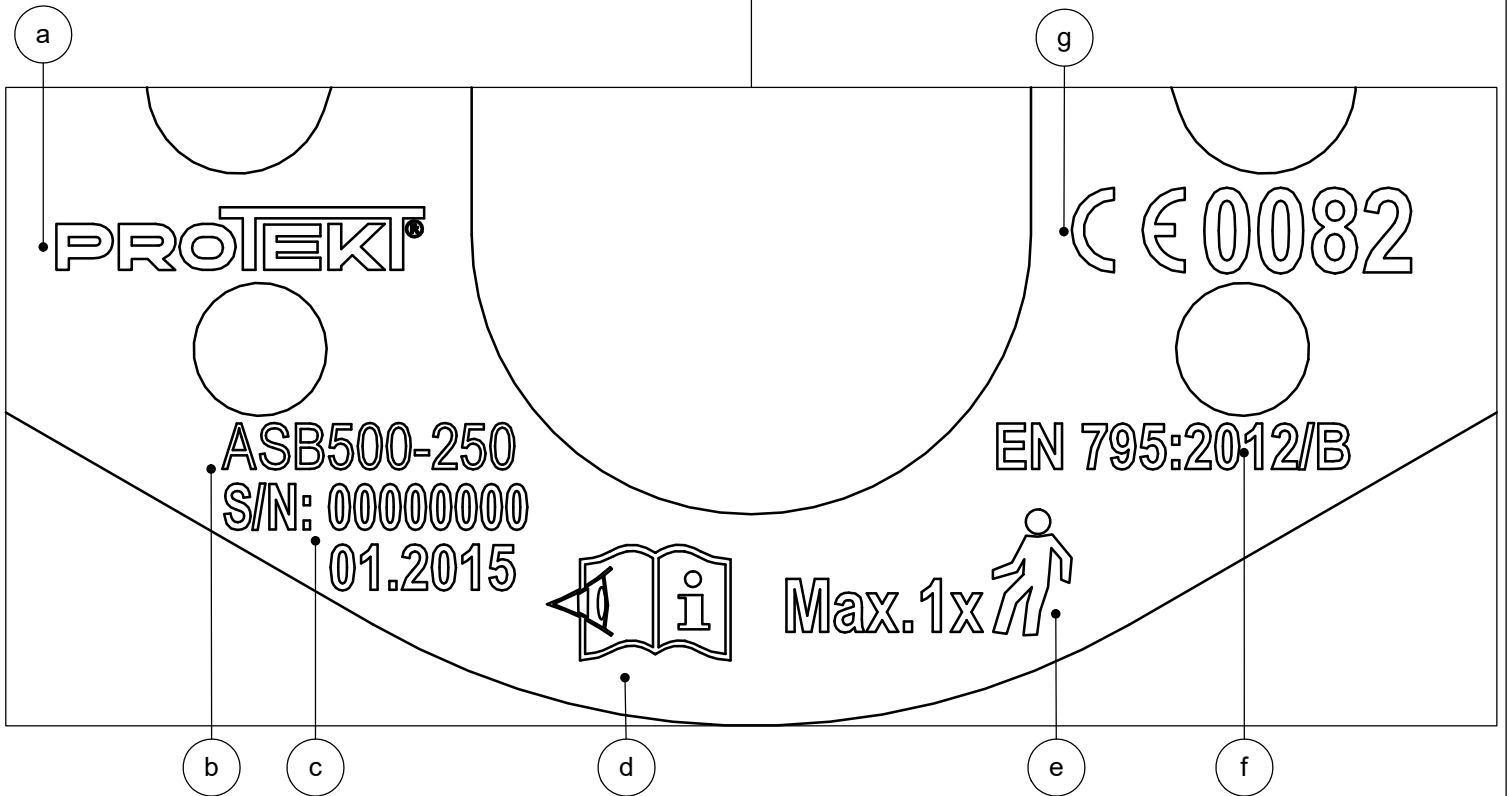
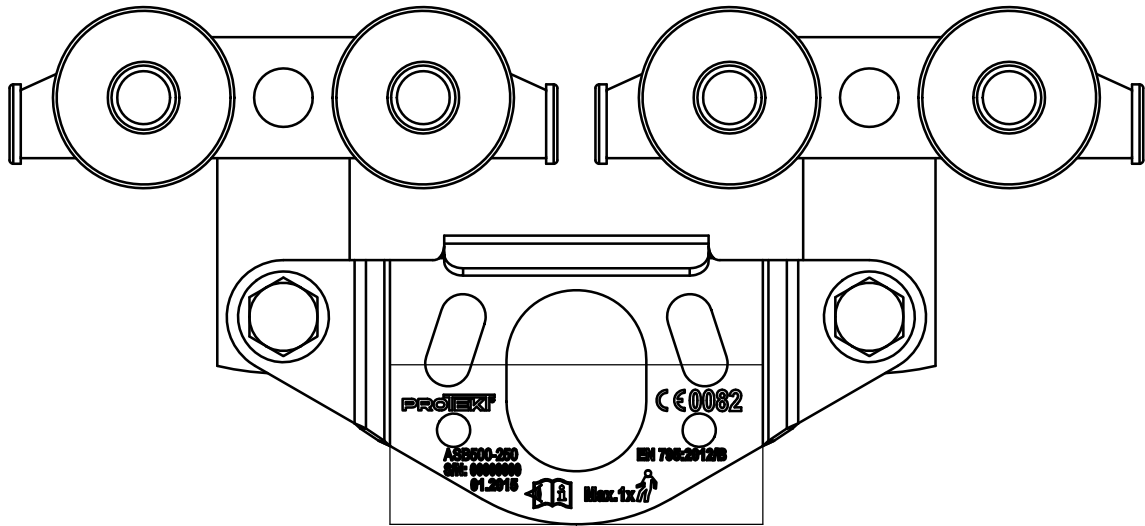

### CONTENT OF INTERNAL TROLLEY MARKING:

- Marking of the manufacturer or distributor.
- Model symbol / reference number.
- Month and year of manufacture / Serial number.
- Caution: read the manual.
- Maximum number of users permitted simultaneously.
- Number / year / type of the European standard.
- CE marking and number of the notified body controlling manufacturing of the equipment.

## SECTION 5

# LIFTING LOADS AND PERSONAL PROTECTION AT THE SAME TIME

**Before read this section please refer to Section 3 and Section 4 (All recommendations contained in these Sections apply in Section 5).**

- HSB device can be used for lifting/lowering loads and personnel protection at the same time.
- For lifting loads external trolley and other lifting equipment can be used.
- For personal protection internal trolley can be used.
- When personnel is protected using internal trolley(s) during lifting/lowering load(s) Working Load Limit (WLL) indicated on the beam must be reduced to the Reduced Working Load Limit (RWLL). RWLL depends on the amount of protected employees.

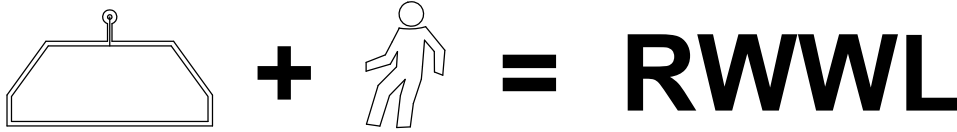

PERMITTED CONFIGURATION	REDUCED WORKING LOAD LIMIT RWLL =
Lifting loads only	RWLL =
Lifting loads + 1 person protected	= WLL - 600kg
Lifting loads + 2 people protected	= WLL - 650kg
Lifting loads + 3 people protected	= WLL - 700kg
Lifting loads + 4 people protected	= WLL - 750kg
Lifting loads + 5 people protected	= WLL - 800kg

**IF RWLL VALUE IS NEGATIVE  
THE DEVICE CANNOT BE USED FOR  
LIFTING/LOWERING LOADS AND PERSONNEL PROTECTION AT THE SAME TIME.**

**example:**

WLL indicated on the HSB 7-meter beam = 3000kg

3 people protected on three internal trolleys

$RWLL = WLL - 700kg = 3000kg - 700 kg = 2300 kg$

results: device can be used at the same time for personnel protection (3 people) and for lifting/lowering loads up to 2300kg.

**GENERAL PECAUTIONS:**

- DO NOT exceed Reduced Working Load Limit (RWLL) during lifting/lowering loads when the people are protected using internal trolleys.
- For personal protection please refer to Section 4!
- For lifting loads please refer to Section 3!

### HSB RWLL VALUE [kg] DEPENDING ON BEAM LENGTH / NUMBER PROTECTED USERS AND FRAME SIZE

	WLL material only		RWLL 1 person		RWLL 2 people		RWLL 3 people		RWLL 4 people		RWLL 5 people	
	T1 / T2	T3	T1 / T2	T3	T1 / T2	T3	T1 / T2	T3	T1 / T2	T3	T1 / T2	T3
<b>3m beam</b>	5000	3000	4400	2400	4350	2350	4300	2300	4250	2250	4200	2200
<b>4m beam</b>	5000	3000	4400	2400	4350	2350	4300	2300	4250	2250	4200	2200
<b>5m beam</b>	5000	3000	4400	2400	4350	2350	4300	2300	4250	2250	4200	2200
<b>6m beam</b>	4000	3000	3400	2400	3350	2350	3300	2300	3250	2250	3200	2200
<b>7m beam</b>	3000	3000	2400	2400	2350	2350	2300	2300	2250	2250	2200	2200

n/a - not applicable

## SECTION 6 - RESCUE ACCORDING TO EN 1496/B

### GENERAL PRECAUTIONS FOR RESCUE:

- Secondary fall arrest system (conforming EN 363) must be used when working with HSB.
- Fall arrest and rescue system used with this device MUST MEET applicable EN standards requirements (EN 795 and TS 16415 for anchor devices; EN 362 for connectors; EN 361 for full body harnesses; EN 360 for retractable type fall arresters; EN 1496 for rescue lifting devices; EN 1497 for rescue harnesses; EN 341 for descender devices).

### USAGE HSB DEVICE FOR RESCUE PURPOSES

- HSB device can be used for rescue purposes in conjunction with ..... rescue lifting devices.
- **During rescue operation lifting/lowering loads IS NOT allowed.**

**UNDER CONSTRUCTION**

### USE LIFTING EQUIPMENT AS PERSONAL PROTECTIVE EQUIPMENT

This device can be used as a personal protective equipment exceptionally according to Directive 2009/104/EC Annex II section 3.1.2.

- While workers are on work equipment designed for lifting loads the control position must be manned at all times.
- Persons being lifted must have reliable means of communication. In the event of danger, there must be reliable means of evacuating them.
- During rescue action always use SDW energy absorber at the end of the rescue lifting device rope.
- Absolutely not exceed the Working Load Limit.
- Be particularly careful. Do not overload these device parts. During the use of equipment for lifting loads for the purpose of personal rescue user must be particularly careful and frequently check the condition of components of the set (rope, pulleys, anchor points).
- For personal rescue purposes safety factor must be, at least 10:1.
- For safety reasons, is better to use two winches (one for lifting loads and one for personal protective use).

# IDENTITY CARD

IT IS RESPONSIBILITY OF THE USER ORGANISATION TO PROVIDE THE IDENTITY CARD AND TO FILL IN THE DETAILS REQUIRED. THE IDENTITY CARD SHOULD BE FILLED IN ONLY BY COMPETENT PERSON RESPONSIBLE FOR PROTECTIVE EQUIPMENT. THE IDENTITY CARD SHOULD BE FILLED IN BEFORE THE FIRST USE OF THE EQUIPMENT. ANY INFORMATION ABOUT THE EQUIPMENT LIKE: PERIODIC INSPECTIONS, REPAIRS, REASONS OF EQUIPMENT'S WITHDRAWN FROM USE SHALL BE NOTED. THE IDENTITY CARD SHOULD BE STORED DURING A WHOLE PERIOD OF EQUIPMENT UTILIZATION. DO NOT USE THE EQUIPMENT WITHOUT THE IDENTITY CARD.

**MODEL AND TYPE OF EQUIPMENT**

**HSB BEAM .....m**

**REF. NUMBER**

**HSB.....-.....**

**SERIAL NUMBER**

**DATE OF MANUFACTURE**

**DATE OF PURCHASE**

**DATE OF FIRST USE**

**USER NAME**

## PERIODIC EXAMINATION AND REPAIR HISTORY

	DATE	REASON FOR SERVICING / REPAIR	REPAIRS CARRIED OUT	NAME AND SIGNATURE OF COMPETENT PERSON	DATE OF NEXT EXAMINATION
1					
2					
3					
4					
5					
6					
7					
8					
9					
10					
11					
12					
13					
14					

**PRODUCER:**

PROTEKT, 93-403 LODZ, ul. Starorudzka 9, POLAND, tel: +48 (42) 680 20 83, fax: +48 (42) 680 20 93, www.protekt.com.pl

# IDENTITY CARD

IT IS RESPONSIBILITY OF THE USER ORGANISATION TO PROVIDE THE IDENTITY CARD AND TO FILL IN THE DETAILS REQUIRED. THE IDENTITY CARD SHOULD BE FILLED IN ONLY BY COMPETENT PERSON RESPONSIBLE FOR PROTECTIVE EQUIPMENT. THE IDENTITY CARD SHOULD BE FILLED IN BEFORE THE FIRST USE OF THE EQUIPMENT. ANY INFORMATION ABOUT THE EQUIPMENT LIKE: PERIODIC INSPECTIONS, REPAIRS, REASONS OF EQUIPMENT'S WITHDRAWN FROM USE SHALL BE NOTED. THE IDENTITY CARD SHOULD BE STORED DURING A WHOLE PERIOD OF EQUIPMENT UTILIZATION. DO NOT USE THE EQUIPMENT WITHOUT THE IDENTITY CARD.

<b>MODEL AND TYPE OF EQUIPMENT</b>	<b>HSB FRAME T....-W....</b>
<b>REF. NUMBER</b>	<b>HSB000-FT...-000</b>
<b>SERIAL NUMBER</b>	.....(A/B)
<b>DATE OF MANUFACTURE</b>	
<b>DATE OF PURCHASE</b>	
<b>DATE OF FIRST USE</b>	
<b>USER NAME</b>	

## PERIODIC EXAMINATION AND REPAIR HISTORY

	<b>DATE</b>	<b>REASON FOR SERVICING / REPAIR</b>	<b>REPAIRS CARRIED OUT</b>	<b>NAME AND SIGNATURE OF COMPETENT PERSON</b>	<b>DATE OF NEXT EXAMINATION</b>
1					
2					
3					
4					
5					
6					
7					
8					
9					
10					
11					
12					
13					
14					

### PRODUCER:

PROTEKT, 93-403 LODZ, ul. Starorudzka 9, POLAND, tel: +48 (42) 680 20 83, fax: +48 (42) 680 20 93, www.protekt.com.pl



# IDENTITY CARD

IT IS RESPONSIBILITY OF THE USER ORGANISATION TO PROVIDE THE IDENTITY CARD AND TO FILL IN THE DETAILS REQUIRED. THE IDENTITY CARD SHOULD BE FILLED IN ONLY BY COMPETENT PERSON RESPONSIBLE FOR PROTECTIVE EQUIPMENT. THE IDENTITY CARD SHOULD BE FILLED IN BEFORE THE FIRST USE OF THE EQUIPMENT. ANY INFORMATION ABOUT THE EQUIPMENT LIKE: PERIODIC INSPECTIONS, REPAIRS, REASONS OF EQUIPMENT'S WITHDRAWN FROM USE SHALL BE NOTED. THE IDENTITY CARD SHOULD BE STORED DURING A WHOLE PERIOD OF EQUIPMENT UTILIZATION. DO NOT USE THE EQUIPMENT WITHOUT THE IDENTITY CARD.

**MODEL AND TYPE OF EQUIPMENT**

**INTERNAL TROLLEY  
(for personal protection)**

**REF. NUMBER**

**ASB500-250**

**SERIAL NUMBER**

**DATE OF MANUFACTURE**

**DATE OF PURCHASE**

**DATE OF FIRST USE**

**USER NAME**

## PERIODIC EXAMINATION AND REPAIR HISTORY

	DATE	REASON FOR SERVICING / REPAIR	REPAIRS CARRIED OUT	NAME AND SIGNATURE OF COMPETENT PERSON	DATE OF NEXT EXAMINATION
1					
2					
3					
4					
5					
6					
7					
8					
9					
10					
11					
12					
13					
14					

**PRODUCER:**

PROTEKT, 93-403 LODZ, ul. Starorudzka 9, POLAND, tel: +48 (42) 680 20 83, fax: +48 (42) 680 20 93, www.protekt.com.pl